



淮洋有限公司 HUI YANG CO.,LTD.

TEL : 886-2-8261-8986 FAX : 886-2-8261-1885

www.hy1688.com.tw 236新北市土城區中央路二段191號10樓之5

2U

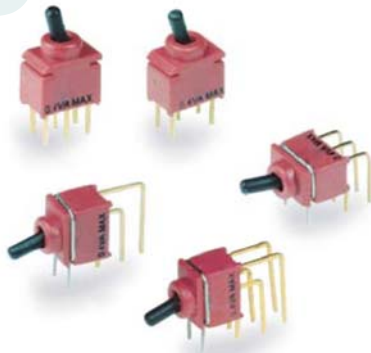

SPECIFICATIONS

MECHANICAL LIFE: 40,000 make-and-break cycles.

CONTACT RATING: 0.4 VA max. @ 20 V AC or DC max.

CONTACT RESISTANCE: Below 100 mΩ typ. initial @ 2-4 V DC, 100 mA.

INSULATION RESISTANCE: 500 MΩ min.

DIELECTRIC STRENGTH: 500 Vrms min. @ sea level.

OPERATING TEMPERATURE: -30°C to 85°C

MATERIALS

HOUSING AND BASE: Glass filled nylon 6/6 or 4/6, flame retardant, heat stabilized (UL94V-0)

ACTUATOR: Glass filled nylon 6/6, flame retardant, heat stabilized (UL94V-0), with standard internal o-ring seal.

SWITCH SUPPORT: Steel, with Sn plate.

CONTACT / TERMINALS: Gold plated Copper alloy.

IP 67
ACCORDING TO
EN 60529:1991+A1:2001
IEC 60529:2001



HOW TO ORDER

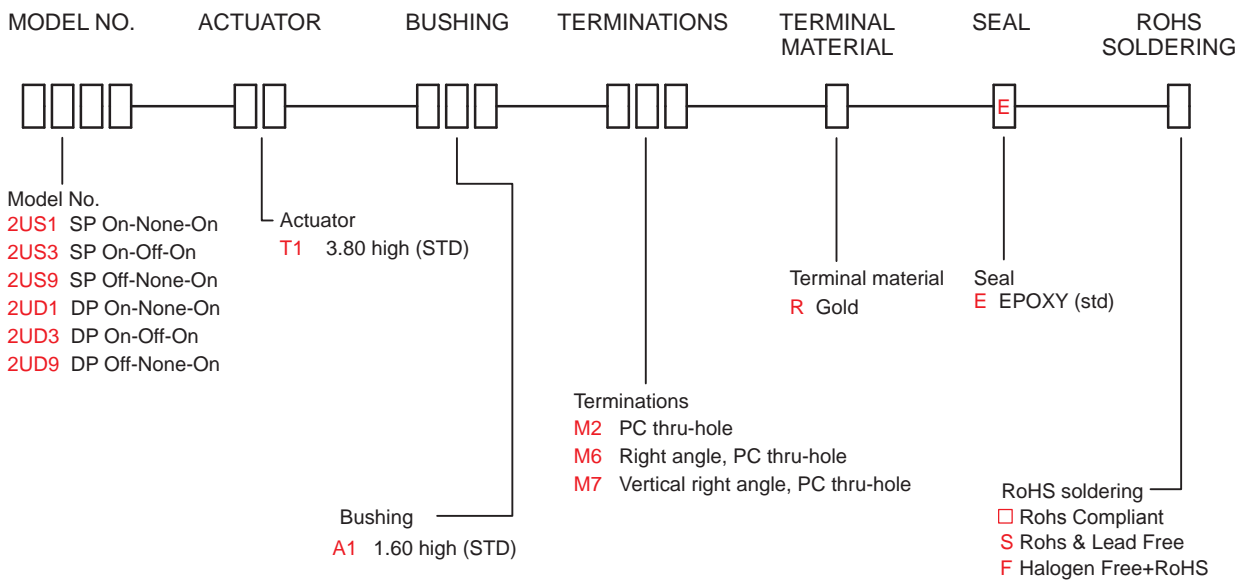

SWITCH FUNCTION

NO. POLES	MODEL NO.	SWITCH FUNCTION			CONNECTED TERMINALS / SCHEMATIC		
		POS.1	POS.2	POS.3	POS.1	POS.2	POS.3
SP	2US1	ON	NONE	ON	5-6	N/A	5-4
	2US3	ON	OFF	ON		OPEN	
	2US9	OFF	NONE	ON	OPEN	N/A	4-6
DP	2UD1	ON	NONE	ON	2-3,5-6	N/A	2-1,5-4
	2UD3	ON	OFF	ON		OPEN	
	2UD9	OFF	NONE	ON	OPEN	N/A	

MOM=MENTORY

POLE OPTIONS

M2

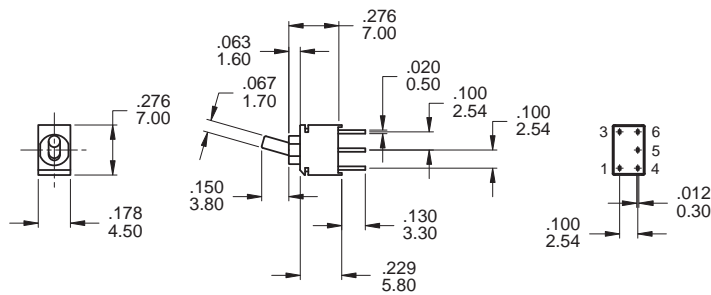

P.C. MOUNTING

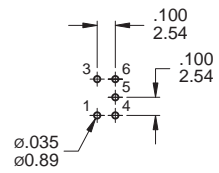

SPDT

Part No. Shown : 2US1T1A1M2RE

M2

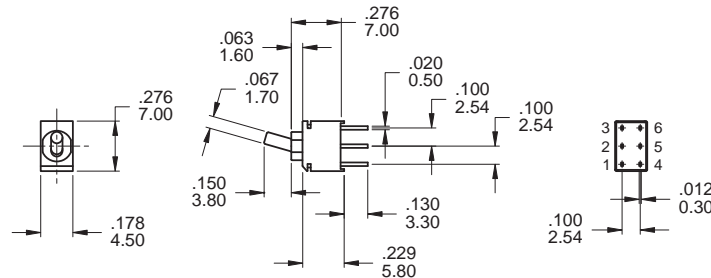

P.C. MOUNTING

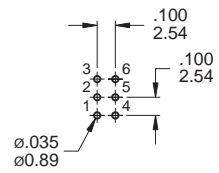

DPDT

Part No. Shown : 2UD1T1A1M2RE

MZ

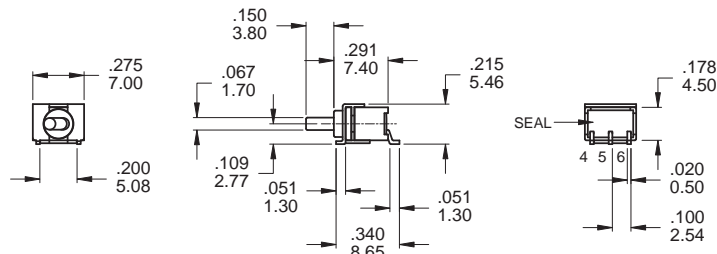

P.C. MOUNTING

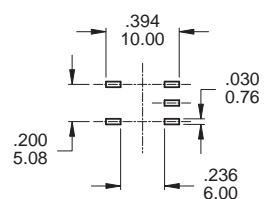

SPDT

Part No. Shown : 2US1T1A1MZRE

M6

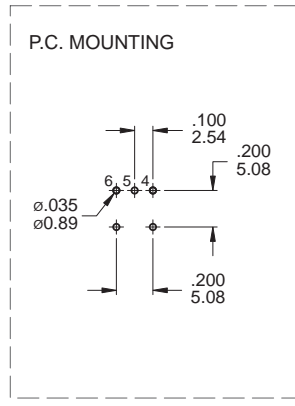
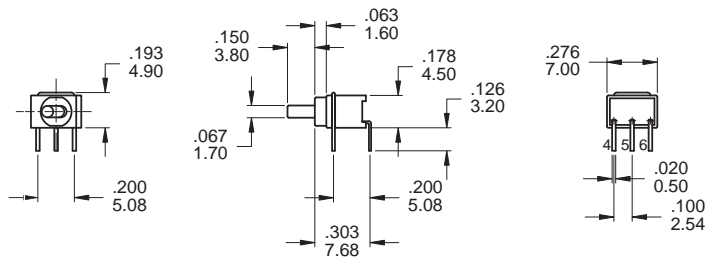

SPDT

Part No. Shown : 2US1T1A1M6RE

M6

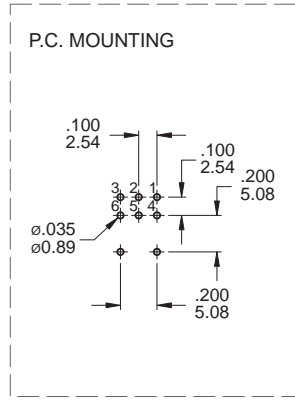
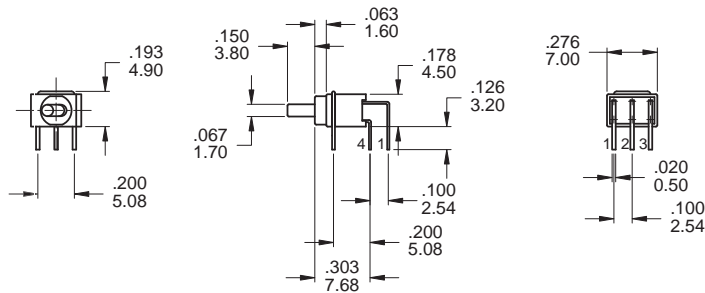

DPDT

Part No. Shown : 2UD1T1A1M6RE

M7

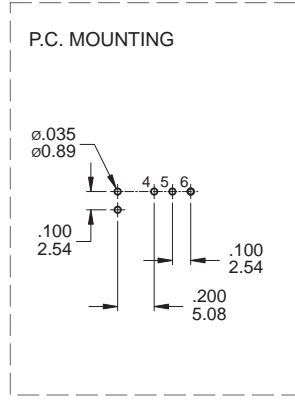
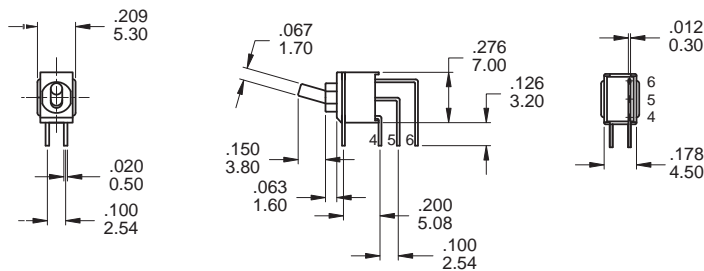

SPDT

Part No. Shown : 2US1T1A1M7RE

M7

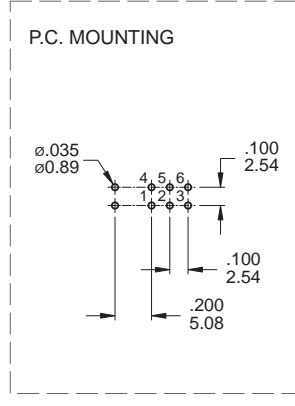
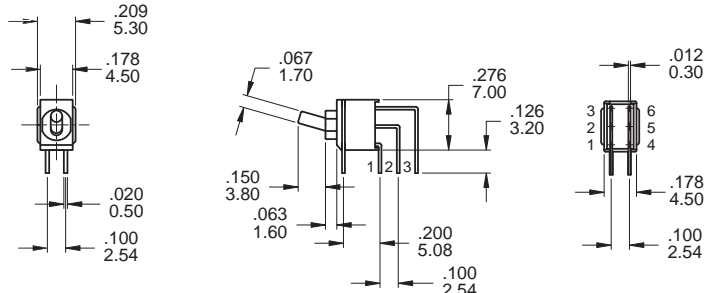
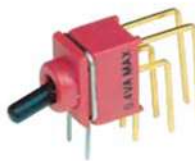

DPDT

Part No. Shown : 2UD1T1A1M7RE

SOLDERING PROCESSES

WAVE SOLDERING: Recommended Soldering Temperature: $260 \pm 5^{\circ}\text{C}$

Duration of Solder Immersion: Max 5 sec.

(PCB is 1.6mm in thickness)

SOLDERING: Vapor phase

Temperature Profile

Zone	Room Temperature	Time (Sec)
Pre-heat (A)	150°C	Min 120s
Soak (B)	180°C ~ 200°C	Min 150s
Peak (C)	200°C ~ 235°C	Min 30s
Peak (D)	235°C ~ 260°C	Min 40s
Peak (E)	260°C	Max 5s

