



淮洋有限公司 HUI YANG CO.,LTD.

TEL : 886-2-8261-8986 FAX : 886-2-8261-1885

www.hy1688.com.tw 236新北市土城區中央路二段191號10樓之5

1F



**SPECIFICATIONS**

**CONTACT RATING:** AC 125V 6A, AC 250V 3A ,DC 30V 3A

**MECHANICAL LIFE:** 100,000 make-and-break cycles  
DC 10V & 0.1mA.

**CONTACT RESISTANCE:** 10 mΩ max.

**INSULATION RESISTANCE:** 500V 500 MΩ min.

**DIELECTRIC STRENGTH:** 1,000 Vrms min. @sea level.

**OPERATING TEMPERATURE:** -30°C to 85°C.

**WATER-RESISTANCE:** 100 make-and-break cycles min at 10 cm depth for T12 actuator.

**MATERIALS**

**CASE:** Diallyl phthalate (DAP) (UL94v-0).

**ACTUATOR:** Brass,chrome plated.

**BUSHING:** Brass,nickel plated.

**HOUSING:** Stainless Steel.

**SWITCH SUPPORT:** Brass,tin plated.

**TERMINAL/CONTACT:** Brass,with silver or gold plated.(See Page 22)



**HOW TO ORDER**

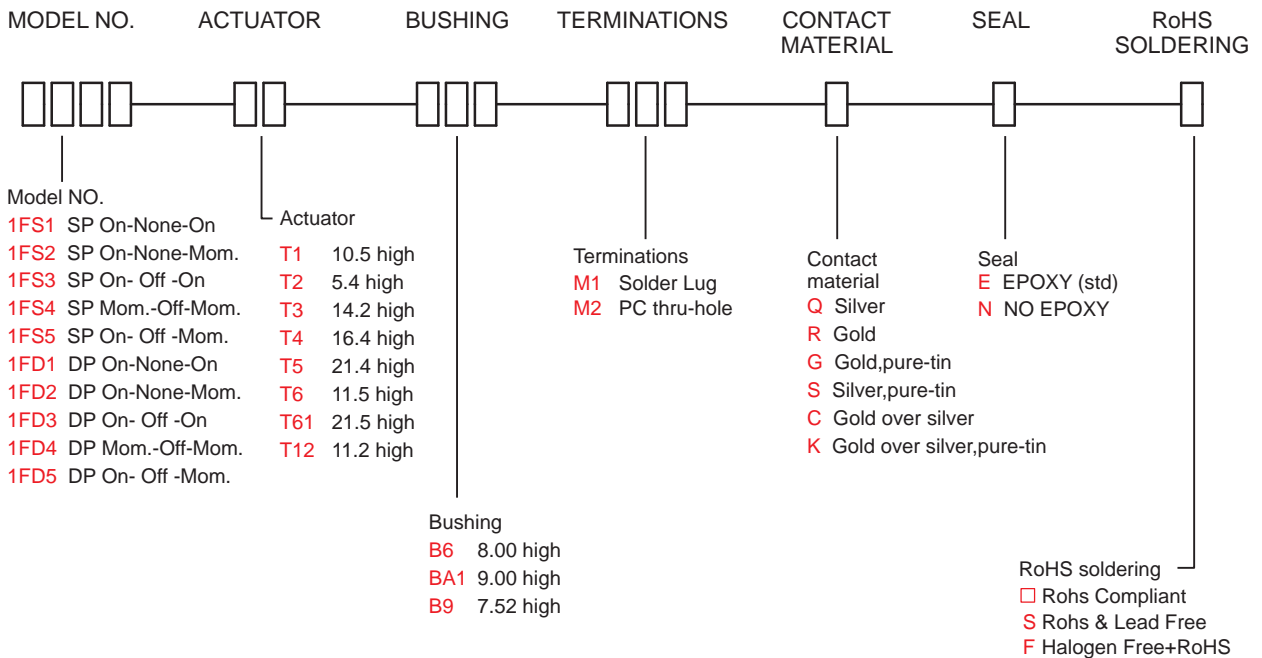

# SWITCH FUNCTION

NO. POLES	MODEL NO.	SWITCH FUNCTION			CONNECTED TERMINALS / SCHEMATIC		
		POS.1	POS.2	POS.3	POS.1	POS.2	POS.3
SP	1FS1	ON	NONE	ON	2-3 	N/A	2-1 
	1FS2	ON	NONE	MOM			
	1FS3	ON	OFF	ON			
	1FS4	MOM	OFF	MOM			
	1FS5	ON	OFF	MOM			
DP	1FD1	ON	NONE	ON	2-3,5-6 	N/A	2-1,5-4 
	1FD2	ON	NONE	MOM			
	1FD3	ON	OFF	ON			
	1FD4	MOM	OFF	MOM			
	1FD5	ON	OFF	MOM			

MOM=MOMENTARY

# ACTUATOR OPTIONS

T1 STD

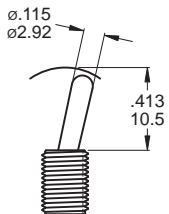

T2

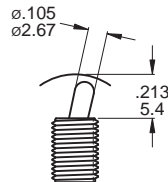

T3

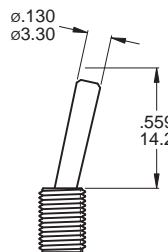

T4

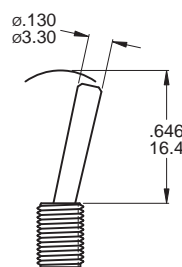

T5

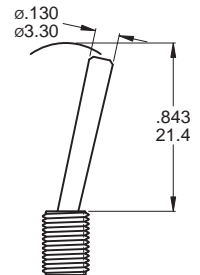

T6 FLATTED WITH ANTIROTATION

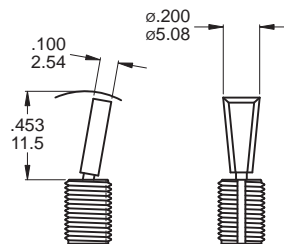

T61

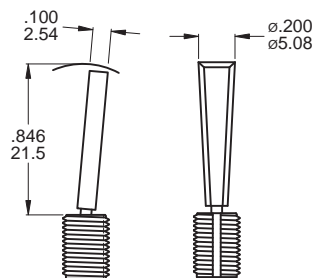

T6,T6-1 use with B6 bushing only

T12

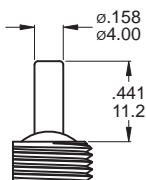

T12 use with BA1 bushing only

\*T12 actuator mechanical life 200,000 cycles

# TERMINATION OPTIONS

M1 Solder lug

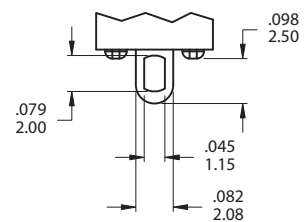

M2 PC Thru - hole

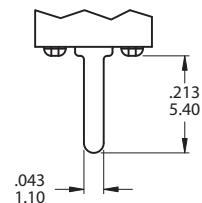

## BUSHING OPTIONS

### B6 HIGH TORQUE

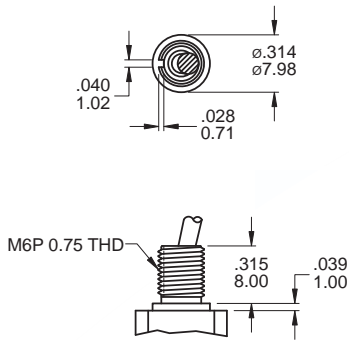

### B9 SPLASH PROOF

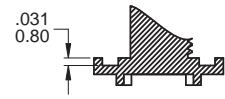
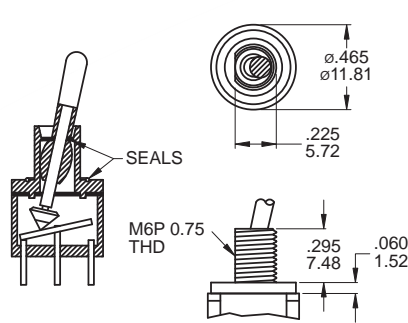

### CP-1TEB

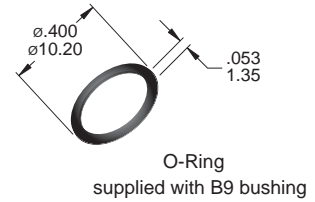

### BA1 SPLASH PROOF

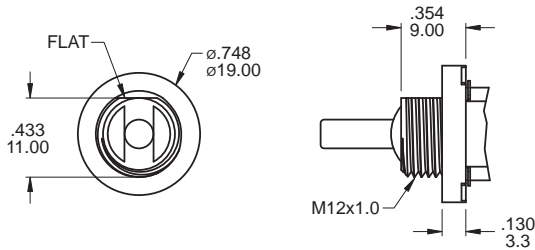

Use with T12 actuators only  
BA1 Bear Strength from top of actuator  
up to 10kg aside up to 15kg

## POLE OPTIONS

### SPDT

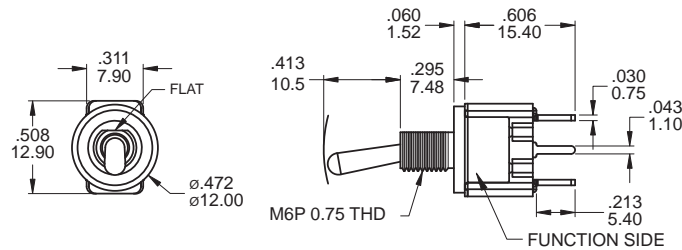

Part No. Shown : 1FS1T1B9M2RES

### DPDT

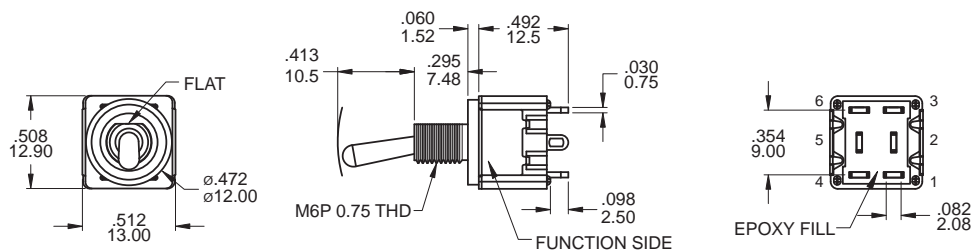

Part No. Shown : 1FD1T1B9M1QES

### SPDT

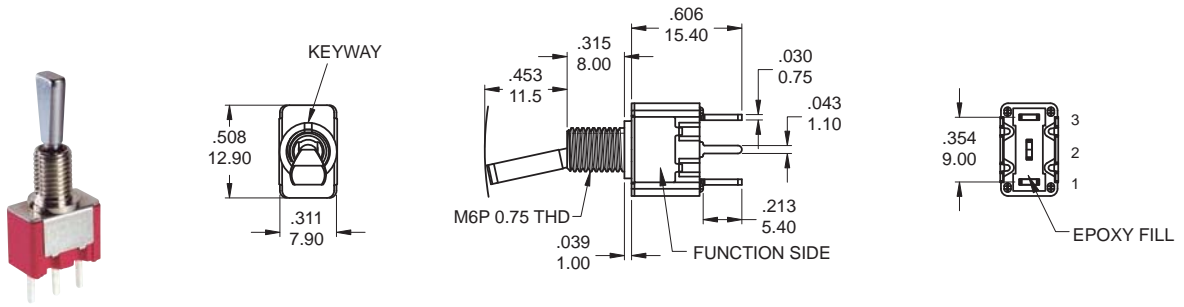

Part No. Shown : 1FS1T6B6M2QES

### DPDT

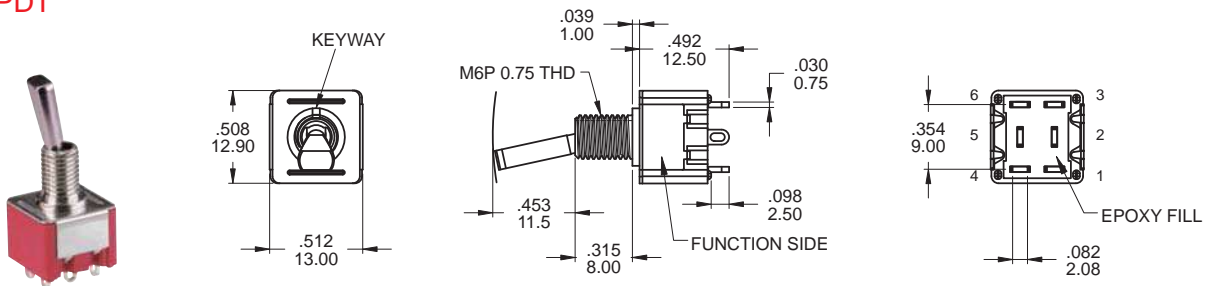

Part No. Shown : 1FD1T6B6M1QES

### SPDT

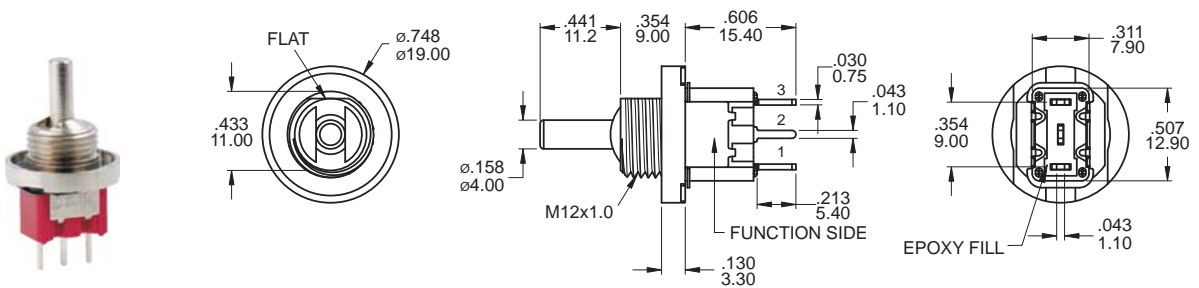

Part No. Shown : 1FS1T12BA1M2QES

### DPDT

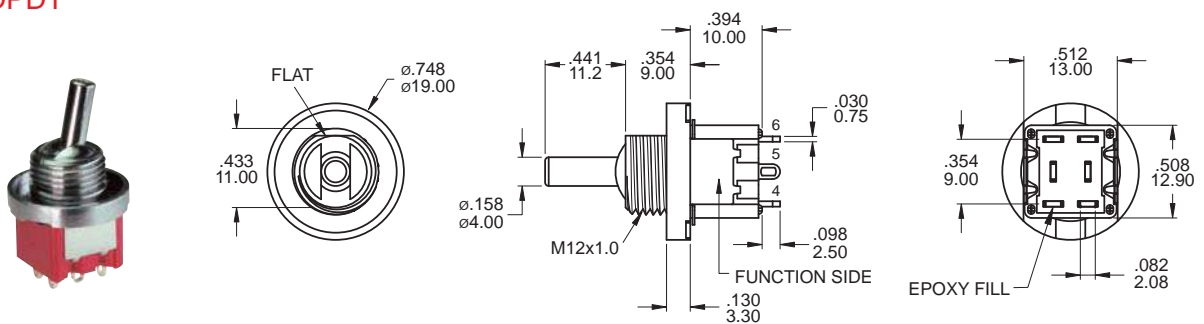

Part No. Shown : 1FD1T12BA1M1QES

## CONTACT MATERIAL OPTIONS

	CONTACT PLATING	TERMINAL PLATING	RATINGS
Q	Silver	Q = Silver	6 Amps with resistant load @ 125VAC or 28VDC 3 Amps with resistant load @ 250VAC
S		S = Silver,pure - tin	
C	Gold over Silver	C = Gold over silver	0.4 Volt - Amps ( VA ) max. @ 20V max. ( AC or DC )
K		K = Gold over silver,pure - tin	
R	Gold	R = Gold	0.4 Volt - Amps ( VA ) max. @ 20V max. ( AC or DC )
G		G = Gold,pure - tin	

## SOLDERING PROCESSES

MANUAL SOLDERING : Use soldering iron of 30 watts, controlled at 350°C  
approximately 5 seconds while applying solder.

WAVE SOLDERING: Recommended Soldering Temperature: 260 ± 5°C

Duration of Solder Immersion: Max 5 sec. (PCB is 1.6mm in thickness)