



淮洋有限公司 HUI YANG CO.,LTD.

TEL : 886-2-8261-8986 FAX : 886-2-8261-1885

www.hy1688.com.tw 236新北市土城區中央路二段191號10樓之5



Feature -

- water proof IP67 sealed
- mini in dimension
- SMT, right angle, and vertical PCB terminal

Application -

- consumer products
- computer products
- instrumentation
- communication equipments



► SPECIFICATIONS

SWITCH SPECIFICATIONS	
POLE - POSITION	Momentary action , SPST
CONTACT RATING	12 V DC , 50 mA
CONTACT RESISTANCE	100 mΩ MAX. 5 V DC ; 1 A , by Method of Voltage DROP
INSULATION RESISTANCE	1000 MΩ MIN. 100 V DC for 1 minute
DIELECTRIC STRENGTH	Breakdown is not Allowable ; 250 V AC for 1 Minute
OPERATING FORCE	200 ± 80 gf ; 450 ± 150 gf
OPERATING LIFE	500,000 cycles
OPERATING TEMPERATURE RANGE	-20°C ~ 70°C
TOTAL TRAVEL	0.45 ± 0.15 mm
SEALING	IP67

► HOW TO ORDER

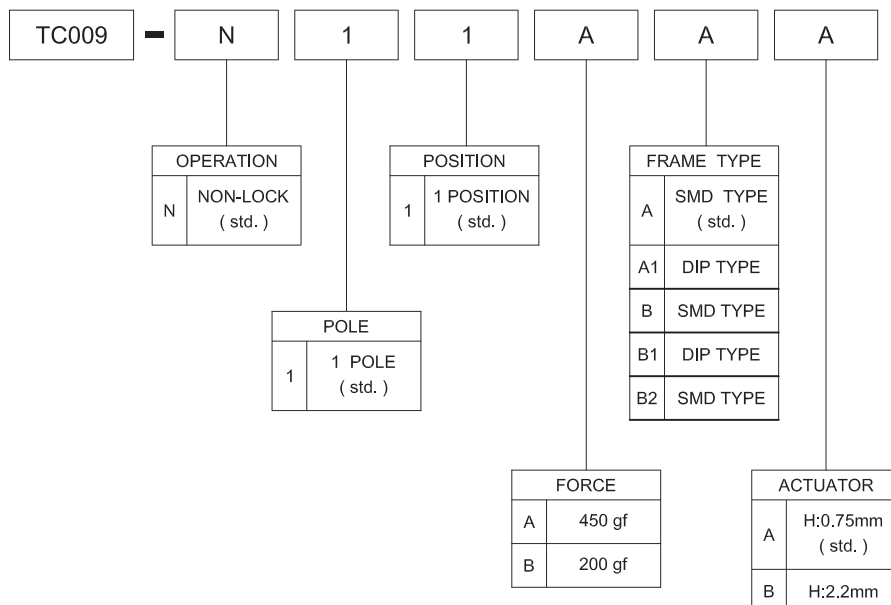

▶ DIMENSION

TC009-N11AAA

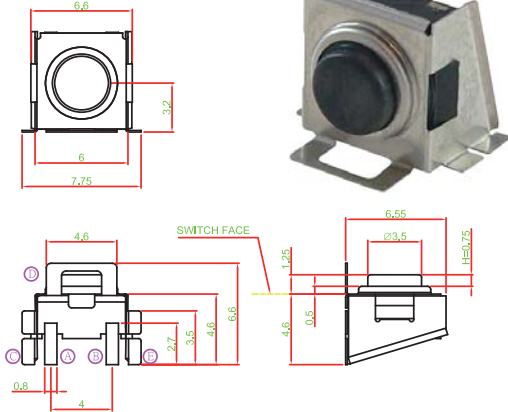

TC009-N11AA1B

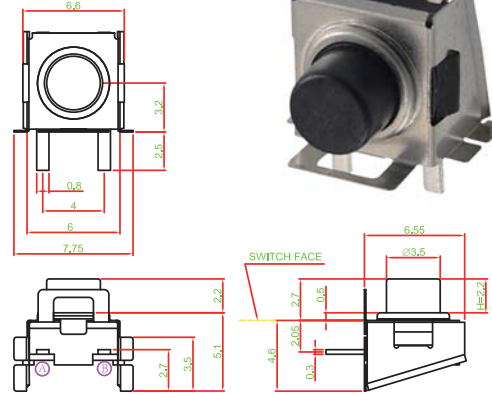

TC009-N11ABA

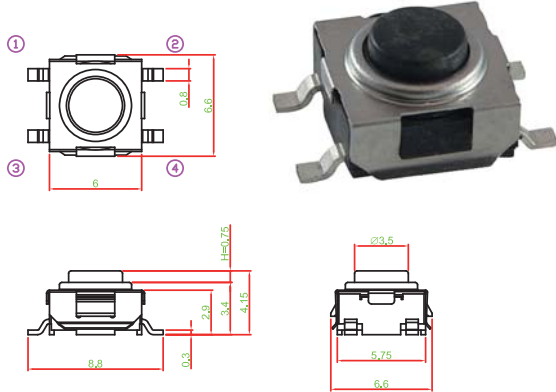

TC009-N11AB1B

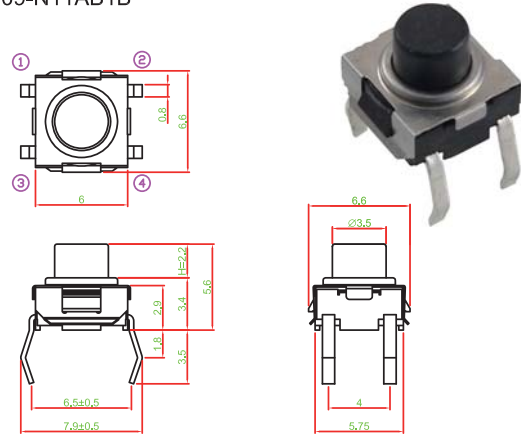

TC009-N11BB2B

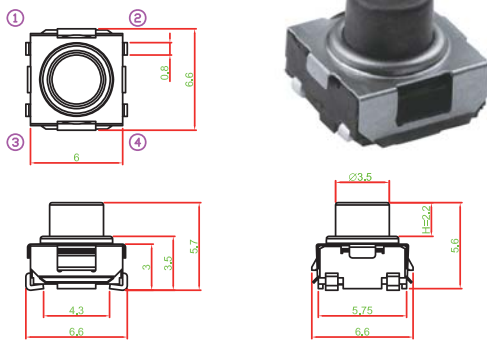

▶ P.C.B. LAYOUT

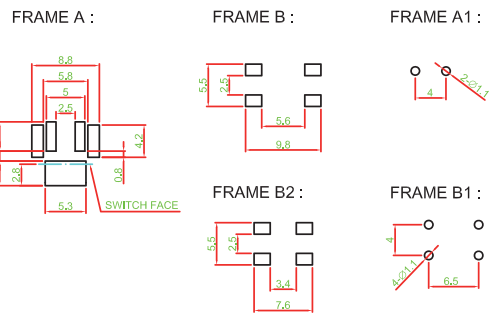

▶ CIRCUIT

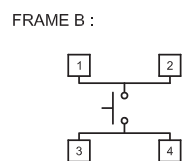
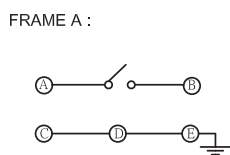

▶ MATERIAL

- COVER : STAINLESS STEEL
- ACTUATOR : LCP+GF
- BASE : LCP+GF
- TERMINAL : BRASS SILVER PLATING
- SPRING PLATE : PHOSPHOR BRONZE SILVER PLATING