

SSS SERIES

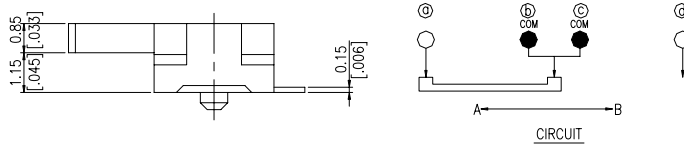

DIMENSION

SS12L

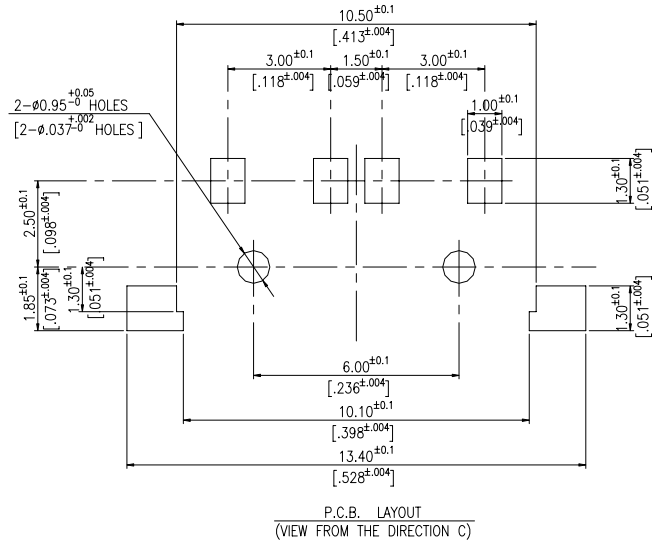
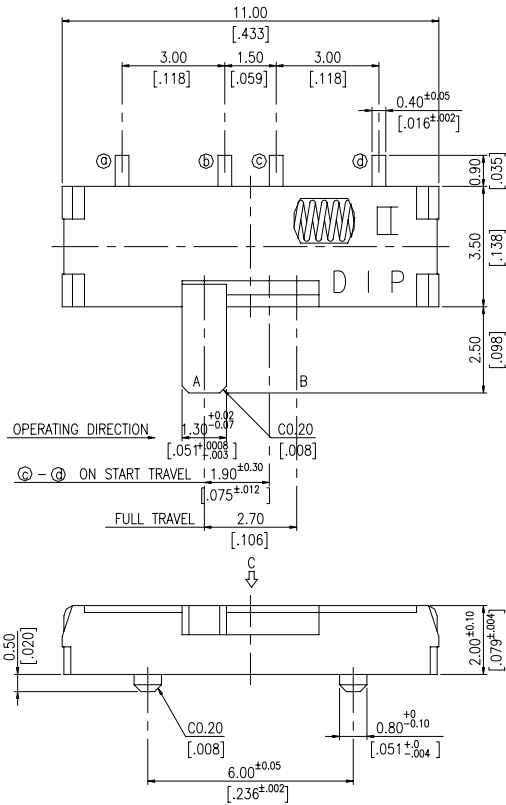

General Tolerance : ±0.2mm

SSS12R

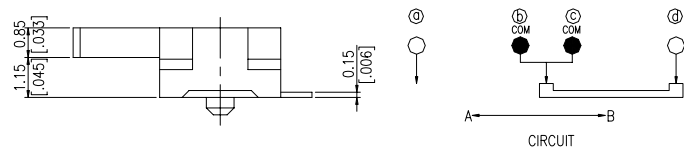
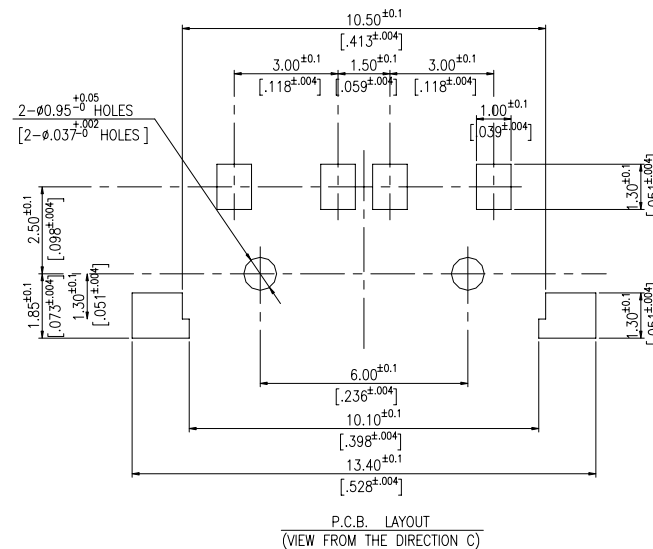
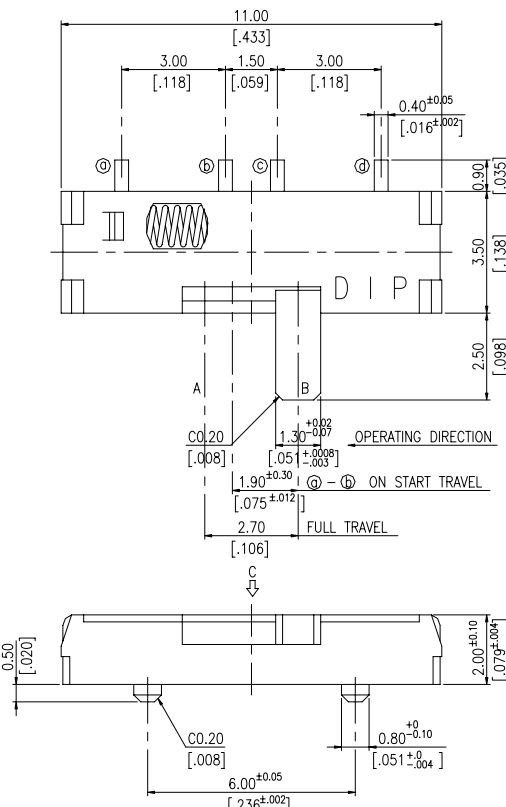

General Tolerance : ±0.2mm

SSS12LG

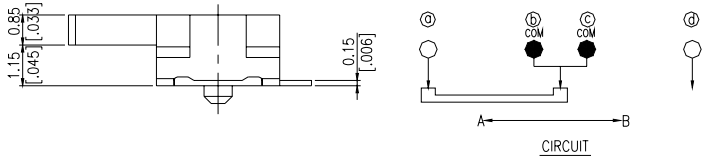
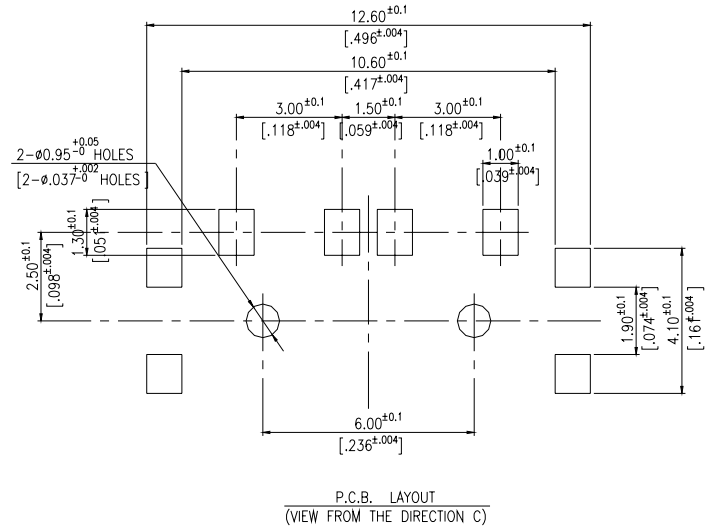
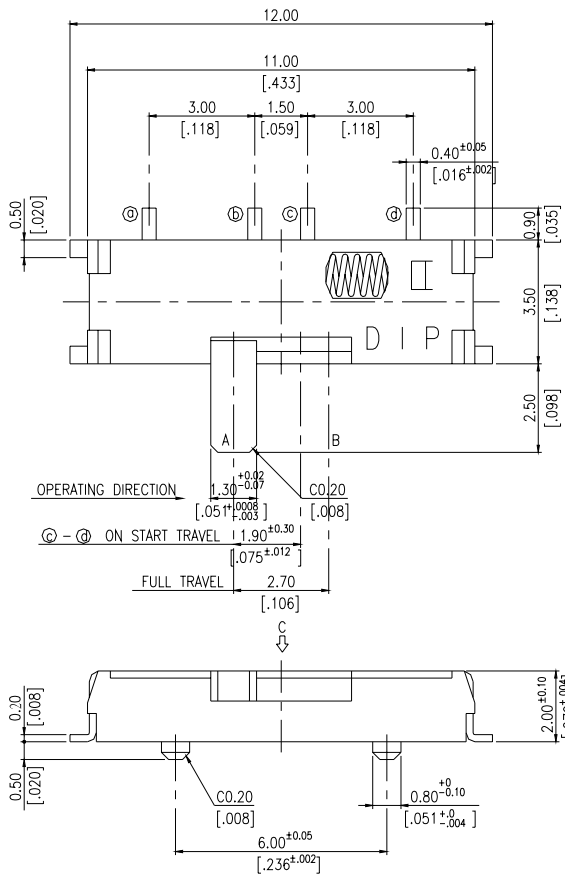

General Tolerance : ±0.2mm

SSS12RG

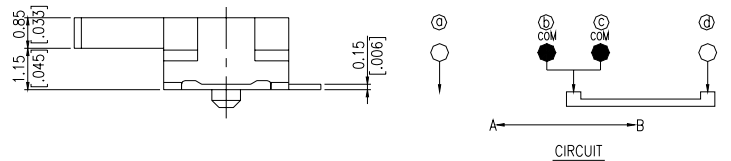
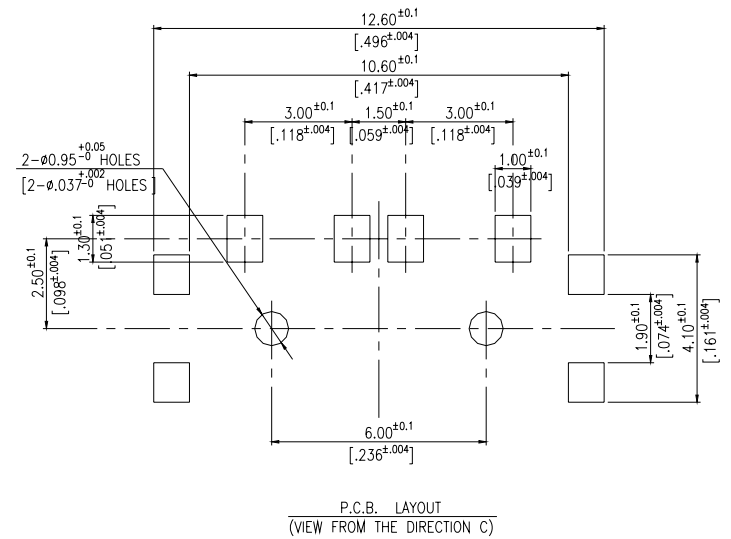
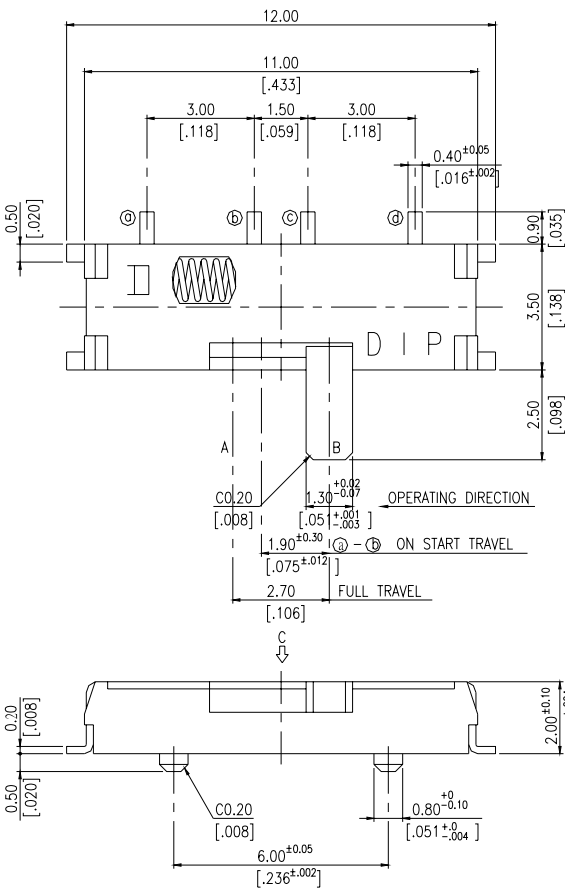

General Tolerance : ±0.2mm

HOW TO ORDER

SSS - 12 □ - V - □

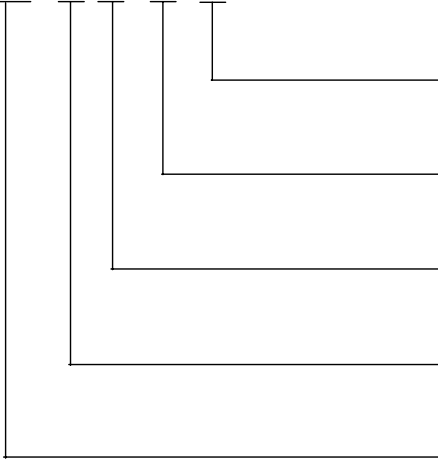

Package :
T/R = Tape & Reel

Soldering :
V = Lead Free Solderable

L = Actuator in Left Side
R = Actuator in Right Side

Poles-Positions
12 = 1P2T

Spring Return Slide Switch

SPECIFICATION

△MECHANICAL

Operation Force : 180 ± 70 gf
Operation Temperature Range : -10°C to $+60^{\circ}\text{C}$
Storage Temperature Range : -20°C to $+75^{\circ}\text{C}$

△ELECTRICAL

Electrical Life : 10,000 cycles
Rating : 25mA, 24V DC
Contact Resistance : $70\text{m}\Omega$ max.
Insulation Resistance : $100\text{M}\Omega$ min. at 100V DC
Dielectric Strength : 100V AC/1 minute
Circuit : 1P2T

MATERIAL

△STEM : UL94V-0 High-Temp Thermoplastic

Color : Black

△COVER : Nickel silver

△SPRING : Stainless silver

△CONTACT : Alloy Copper, Gold Plated

△BASE : LCP High-Temp Thermoplastic

Color : Black

△TERMINAL : Phosphor Bronze, with Silver plated

SOLDERING PROCESS

△HAND SOLDERING : Use a soldering iron of 30 watts, Controlled at 350°C approximately 5 seconds while applying solder.

△REFLOW SOLDERING : When applying reflow soldering, the peak temperature or the reflow oven should be set to 260°C max.

△Temperature Profile :

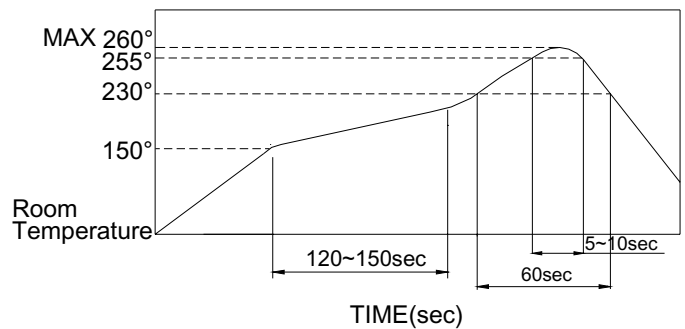

PACKING

REEL

Part Number	Number Per Tube	Number Per Reel
SSS-12R(G)	-	2000
SSS-12L(G)	-	2000

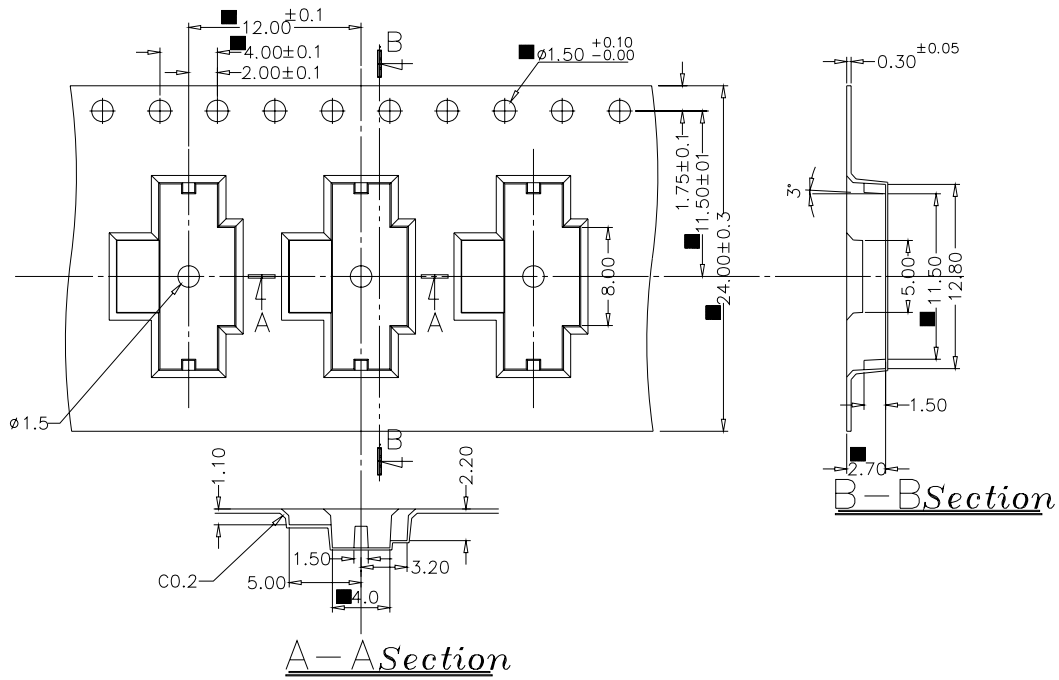

General Tolerance : $\pm 0.1\text{mm}$