



淮洋有限公司 HUI YANG CO., LTD.

TEL : 886-2-8261-8986 FAX : 886-2-8261-1885

www.hy1688.com.tw 236新北市土城區中央路二段191號10樓之5

SENSOR SWITCH

Item No.	RBS3302 系列	Description	ROLL BALL SWITCH	Version	8
Page	1 of 16	Date		Nov. 12, 2013	

● 功能

1. 全周 360°傾倒偵測
2. 震動偵測



● 應用

1. 家電傾倒自動斷電系統
2. 運動器材斷電安全裝置
3. 警報系統
4. 防盜、防篡改裝置
5. 生物移動偵測
6. 系統喚醒裝置
7. 機車傾斜自動斷電
8. 地震感測





淮 洋 有 限 公 司 HUI YANG CO.,LTD.

TEL : 886-2-8261-8986 FAX : 886-2-8261-1885

www.hy1688.com.tw 236新北市土城區中央路二段191號10樓之5

SENSOR SWITCH

Item No.	RBS3302 系列	Description	ROLL BALL SWITCH	Version	8
Page	2 of 16		Date	Nov. 12, 2013	

● 特性

1. 外殼採用高絕緣性塑膠材料，可避免外殼導電或生鏽。
2. 採用光電晶體感測訊號，不受金屬氧化或磨損的影響。
3. 所有塑膠材料均使用高耐溫之工程塑膠。
4. 開關訊號單純，線路設計容易。
5. 適用於水平電路板。
6. 傾斜角度：15°、20°、30°、45°角四種選擇，全周 360°角皆可檢測無死角。
7. 符合 RoHS 標準，完全替代水銀開關。
8. 比 IC 設計經濟的解決方案。
9. 台灣製造，出廠全檢。





淮洋有限公司 HUI YANG CO., LTD.

TEL : 886-2-8261-8986 FAX : 886-2-8261-1885

www.hy1688.com.tw 236新北市土城區中央路二段191號10樓之5

SENSOR SWITCH

Item No.	RBS3302 系列	Description	ROLL BALL SWITCH	Version	8
Page	3 of 16	Date		Nov. 12, 2013	

● 尺寸 / 運用 / 電路板佈線圖 (單位: mm,公差: ±0.25mm)

(圖 1)

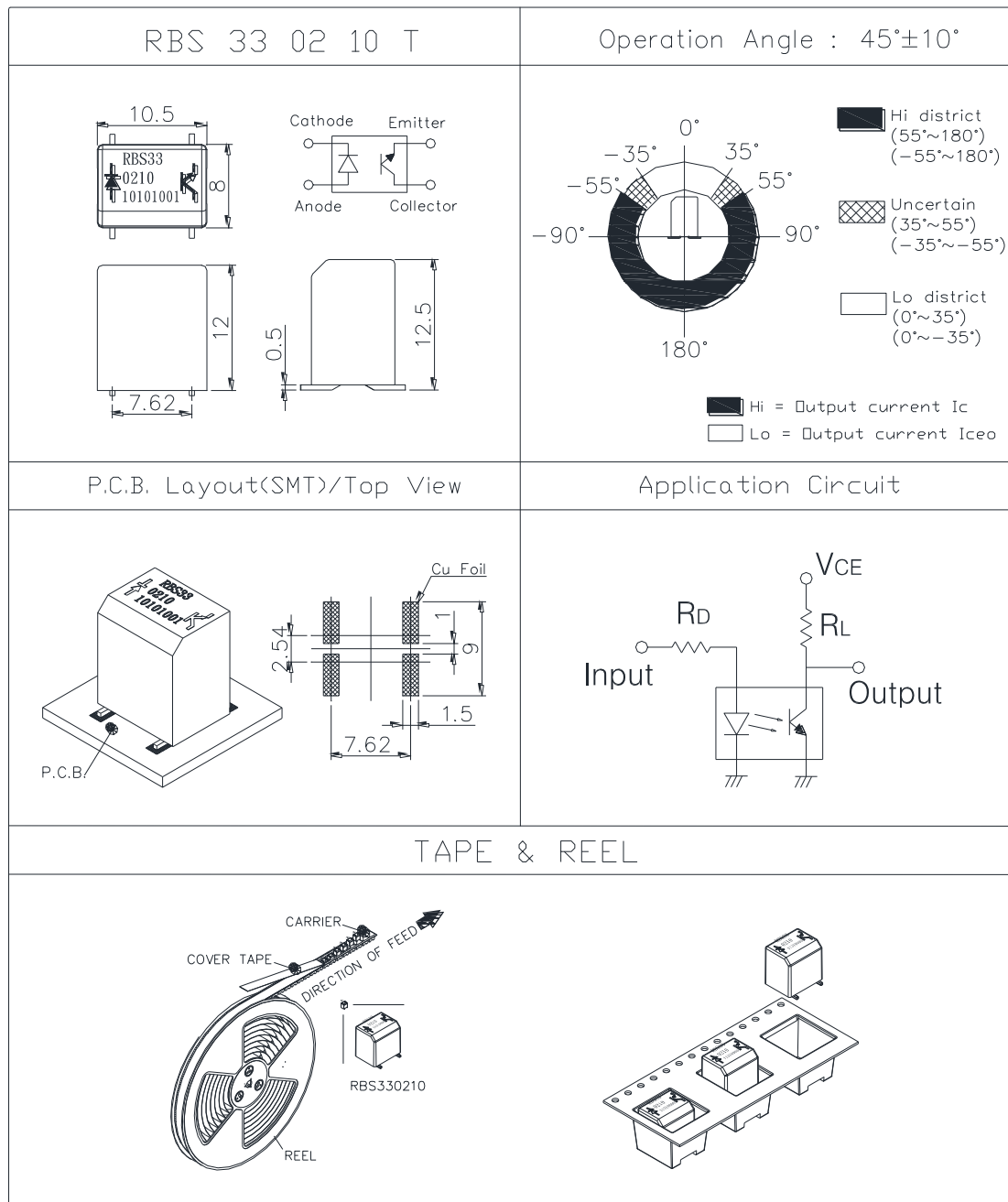



淮洋有限公司 HUI YANG CO., LTD.

TEL : 886-2-8261-8986 FAX : 886-2-8261-1885

www.hy1688.com.tw 236新北市土城區中央路二段191號10樓之5

SENSOR SWITCH

Item No.	RBS3302 系列	Description	ROLL BALL SWITCH	Version	8
Page	4 of 16	Date		Nov. 12, 2013	

(圖 2)

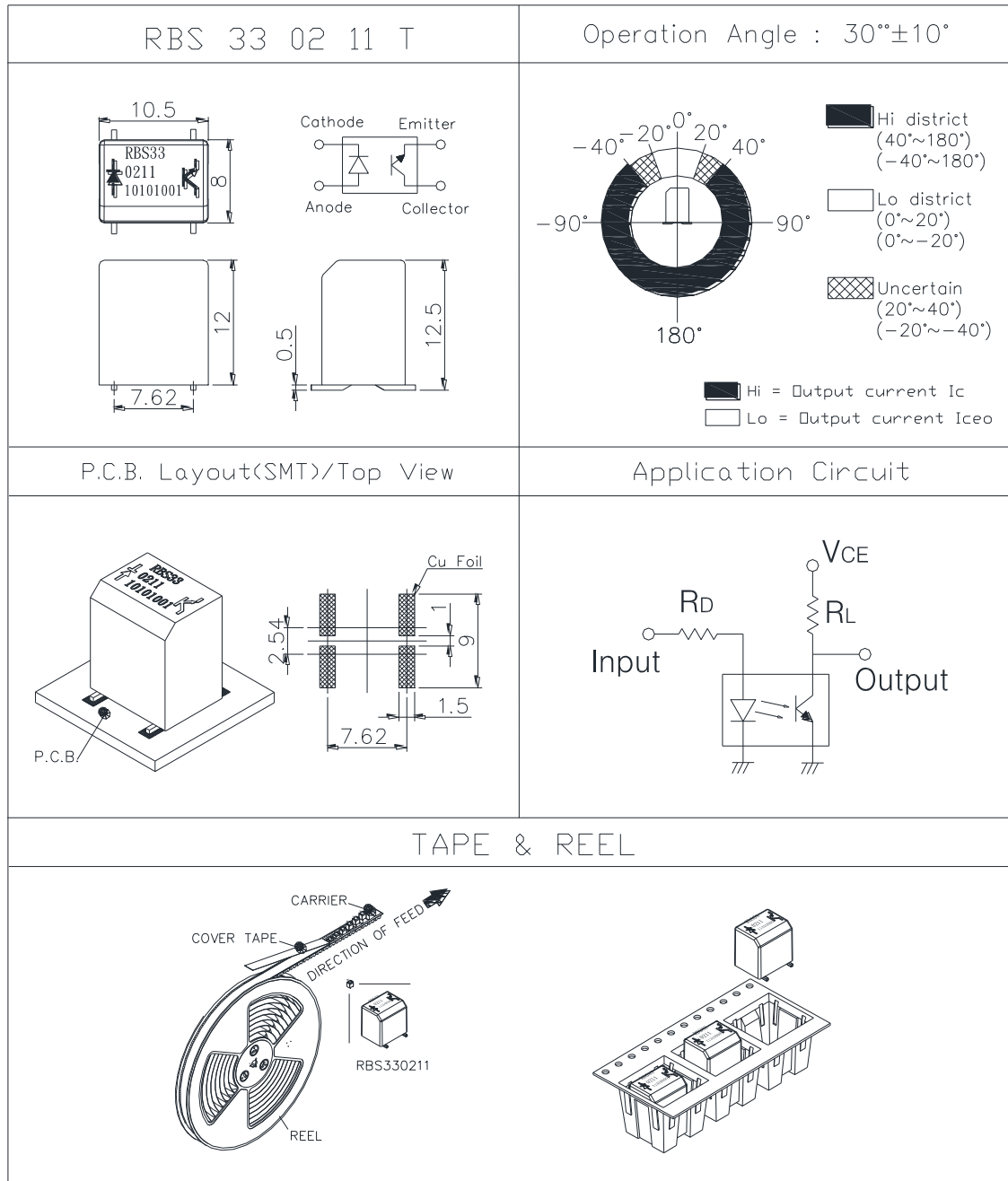



淮洋有限公司 HUI YANG CO., LTD.

TEL : 886-2-8261-8986 FAX : 886-2-8261-1885

www.hy1688.com.tw 236新北市土城區中央路二段191號10樓之5

SENSOR SWITCH

Item No.	RBS3302 系列	Description	ROLL BALL SWITCH	Version	8
Page	5 of 16	Date		Nov. 12, 2013	

(圖 3)

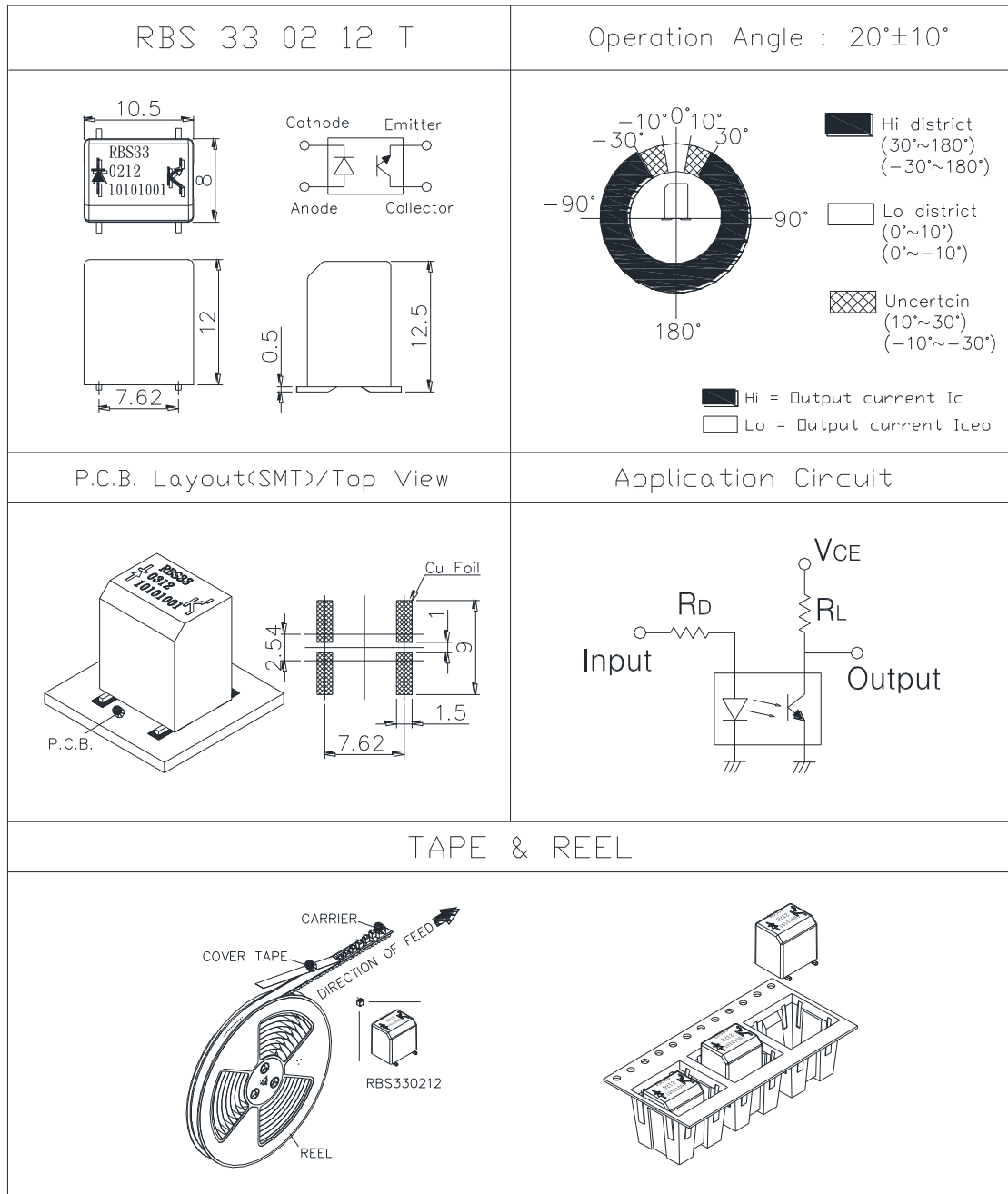



淮洋有限公司 HUI YANG CO., LTD.

TEL : 886-2-8261-8986 FAX : 886-2-8261-1885

www.hy1688.com.tw 236新北市土城區中央路二段191號10樓之5

SENSOR SWITCH

Item No.	RBS3302 系列	Description	ROLL BALL SWITCH	Version	8
Page	6 of 16	Date		Nov. 12, 2013	

(圖 4)

RBS 33 02 13 T		Operation Angle : $15^\circ \pm 10^\circ$	
P.C.B. Layout(SMT)/Top View		Application Circuit	
TAPE & REEL			





淮洋有限公司 HUI YANG CO., LTD.

TEL : 886-2-8261-8986 FAX : 886-2-8261-1885

www.hy1688.com.tw 236新北市土城區中央路二段191號10樓之5

SENSOR SWITCH

Item No.	RBS3302 系列	Description	ROLL BALL SWITCH	Version	8
Page	7 of 16		Date	Nov. 12, 2013	

● 建議電流、電壓條件

輸入電流 (mA)	操作電壓 (V)	條件
10	5	$V_{CE}=5V$ $R_D=470\text{ ohm}$ $R_L=33K\text{ ohm}$

● Absolute Maximum Rating ($T_a=25^\circ C$)

Item		Symbol	Rating	Unit
Input	Power Dissipation	P_d	75	mW
	Reverse Voltage	V_R	5	V
	Forward Current	I_F	50	mA
	Peak Forward Current (*1)	I_{FP}	1	A
Output	Collector Power Dissipation	P_C	100	mW
	Collector Current	I_C	20	mA
	C-E Voltage	V_{CEO}	30	V
	E-C Voltage	V_{ECO}	5	V
Operating Temperature		T_{opr}	-25~+85	$^\circ C$
Storage Temperature		T_{stg}	-40~+85	$^\circ C$
Soldering Temperature (*2)		T_{sol}	260	$^\circ C$

(*1) $t_w=100\text{ uSec.}$ 、 $T=10\text{ mSec.}$

(*2) $t=5\text{ Sec}$





淮洋有限公司 HUI YANG CO., LTD.

TEL : 886-2-8261-8986 FAX : 886-2-8261-1885

www.hy1688.com.tw 236新北市土城區中央路二段191號10樓之5

SENSOR SWITCH

Item No.	RBS3302 系列	Description	ROLL BALL SWITCH	Version	8
Page	8 of 16		Date	Nov. 12, 2013	

● 光電、電性特性 (Ta=25°C)

Parameter	Symbol	Condition	Min.	Typ.	Max.	Unit
Forward Voltage	V_F	$I_F=20mA$	-	1.2	1.5	V
Reverse Current	I_R	$V_R=5V$	-	-	10	μA
Peak Wavelength	λ_p	$I_F=10mA$		940		nm
Dark Current	I_{ceo}	$V_{CE}=10V$	-	-	2	μA
C-E Saturation Voltage	$V_{CE} (sat)$	$I_C=0.25mA$ $I_F=20mA$	-	-	0.4	V
Light Current	I_C	$V_{CE}=5V$ $I_F=20mA$	0.5	5	-	mA
Rise Time	T_r	$I_C=0.8mA$ $V_{CC}=30V$	-	5	-	μsec
Fall Time	T_f	$R_L=1K\Omega$	-	5	-	μsec





淮洋有限公司 HUI YANG CO., LTD.

TEL : 886-2-8261-8986 FAX : 886-2-8261-1885

www.hy1688.com.tw 236新北市土城區中央路二段191號10樓之5

SENSOR SWITCH

Item No.	RBS3302 系列	Description	ROLL BALL SWITCH	Version	8
Page	9 of 16		Date	Nov. 12, 2013	

● 光電、電性特性曲線 (Ta=25°C)

Fig.1 Power Dissipation vs. Ambient Temperature

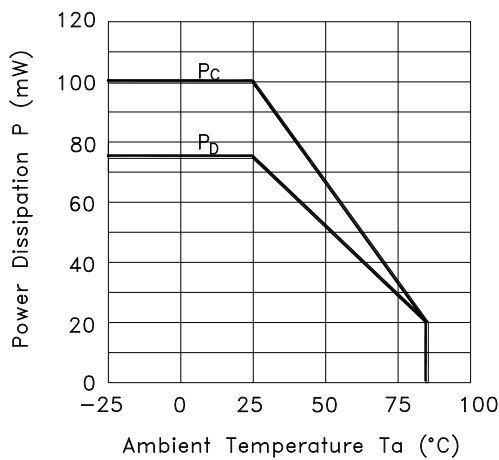

Fig.2 Forward Current vs. Forward Voltage

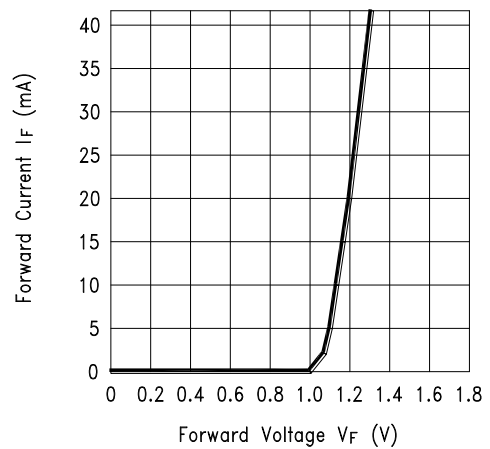

Fig.3 Collector Current vs. Collector-emitter Voltage

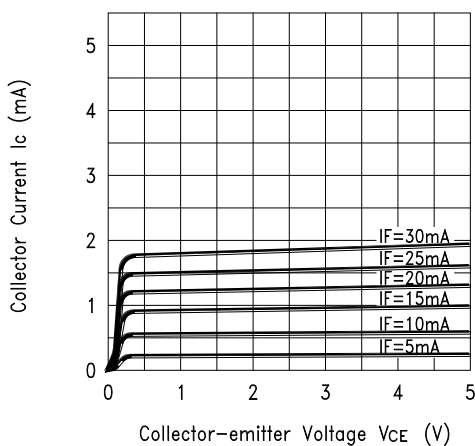
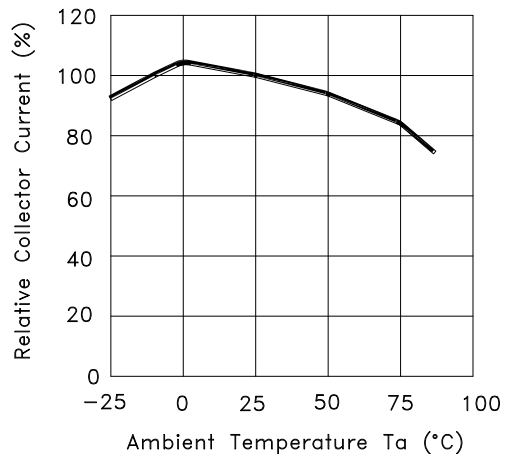

Fig.4 Collector Current vs. Ambient Temperature





淮洋有限公司 HUI YANG CO., LTD.

TEL : 886-2-8261-8986 FAX : 886-2-8261-1885

www.hy1688.com.tw 236新北市土城區中央路二段191號10樓之5

SENSOR SWITCH

Item No.	RBS3302 系列	Description	ROLL BALL SWITCH	Version	8
Page	10 of 16	Date		Nov. 12, 2013	

Fig.5 Collector-emitter Saturation Voltage vs. Ambient Temperature

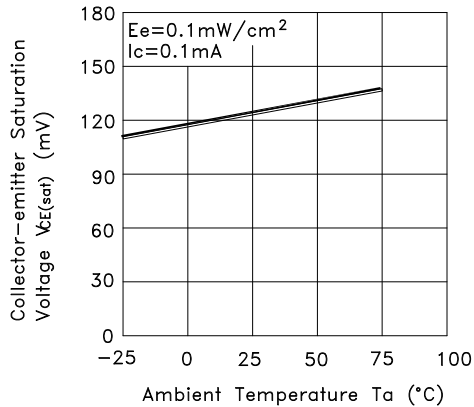

Fig.6 Response Time vs. Load Resistance

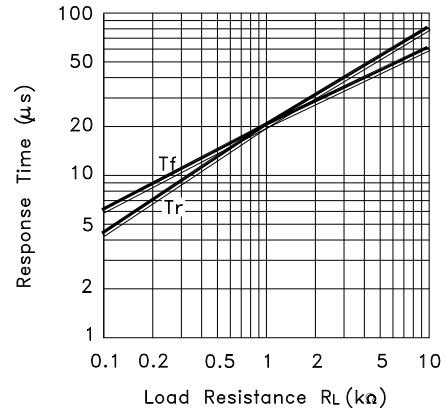
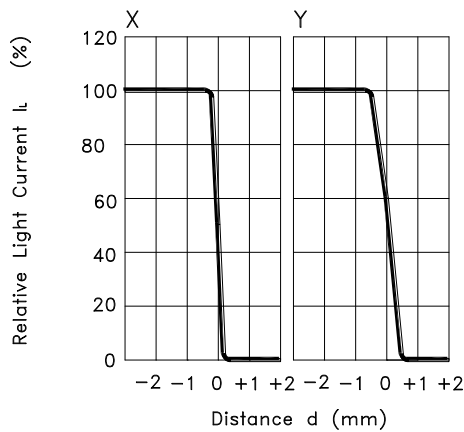
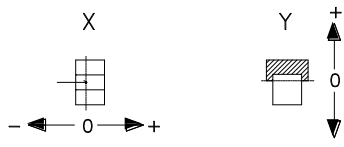

Fig.7 Sensing Position Characteristics (Typical)



(Center of Optical axis)



Test Circuit for Response Time

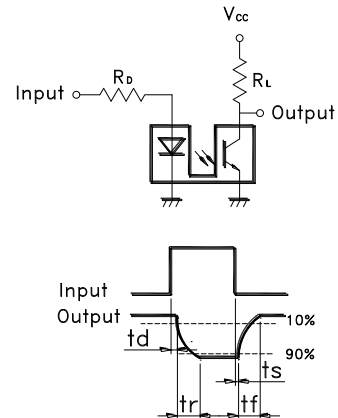



淮 洋 有 限 公 司 HUI YANG CO.,LTD.

TEL : 886-2-8261-8986 FAX : 886-2-8261-1885

www.hy1688.com.tw 236新北市土城區中央路二段191號10樓之5

SENSOR SWITCH

Item No.	RBS3302 系列	Description	ROLL BALL SWITCH	Version	8
Page	11 of 16		Date	Nov. 12, 2013	

● 電性/電氣特性

1	接點容量	--
2	接觸電阻	--
3	角度差	參考圖 1~圖 4
4	絕緣電阻	--
5	介電強度	--
6	電容量	--

● 可靠度測試項目

以下的表格呈現的是 RBS3302 系列的壽命、機械、與環境測試。

測試項目	依據規範	測試內容
迴焊爐	MIL-STD-202G, TEST METHOD 210F, IPC/JEDEC J-STD-020D	Peak temp.=255~260°C *3times
操作溫度	MIL-STD-202G, TEST METHOD 107G, TEST A	-25°C~85°C
儲存溫度	MIL-STD-202G, TEST METHOD 107G, TEST A	-40°C~85°C
濕 度	MIL-STD-202G, TEST METHOD 103B	40°C/95%RH
機械壽命	--	2Hz, horizontal 1,000,000 times
電氣壽命	MIL-STD-883E:1016	IF=20 mA VCE=5 V TIME: 30,000 hrs





淮洋有限公司 HUI YANG CO., LTD.

TEL : 886-2-8261-8986 FAX : 886-2-8261-1885

www.hy1688.com.tw 236新北市土城區中央路二段191號10樓之5

SENSOR SWITCH

Item No.	RBS3302 系列	Description	ROLL BALL SWITCH	Version	8
Page	12 of 16		Date	Nov. 12, 2013	

● 焊錫條件

以下焊錫條件僅供參考，建議使用者依照焊劑製造商推薦的焊接檔案資料來進行。

操作方式 \ 條件	焊接溫度	焊接時間	烙鐵瓦數	適用製程
迴流焊接	詳如以下迴焊資料及(圖 5)		-	SMT
波峰焊接	260±5°C	< 5 seconds max.	-	DIP
烙鐵焊接	260±5°C	< 5 seconds max.	20W 或 溫控烙鐵	DIP、SMT





淮 洋 有 限 公 司 HUI YANG CO.,LTD.

TEL : 886-2-8261-8986 FAX : 886-2-8261-1885

www.hy1688.com.tw 236新北市土城區中央路二段191號10樓之5

SENSOR SWITCH

Item No.	RBS3302 系列	Description	ROLL BALL SWITCH	Version	8
Page	13 of 16		Date	Nov. 12, 2013	

< 迴焊資料分類表 >

主要項目	有鉛製程	無鉛製程
預熱與浸泡		
溫度最小值(Tsmin)	100 °C	150 °C
溫度最大值(Tsmax)	150 °C	200 °C
時間(Tsmin to Tsmax)(ts)	60-120 seconds	60-120 seconds
平均爬升率(Tsmax to Tp)	3 °C/second max.	3 °C/second max.
液化溫度 (TL)	183 °C	217 °C
液化時間 (tL)	60-150 seconds	60-150 seconds
峰值封裝主體溫度(Tp)*	230 °C ~235 °C *	255 °C ~260 °C *
分級溫度(Tc)	235 °C	260 °C
分級溫度(Tc)在 5 °C 之內 的 確切時間(tp)**	20** seconds	30** seconds
平均下降率 (Tp toTsmax)	6 °C/second max.	6 °C/second max.
25 °C 至溫度尖峰的時間	6 minutes max.	8 minutes max.
*溫度曲線尖峰值 (Tp) : 溫度公差的定義為供應者的最小值與使用者的最大值		
**溫度曲線尖峰值 (tp) : 時間公差的定義為供應者的最小值與使用者的最大值		





淮洋有限公司 HUI YANG CO., LTD.

TEL : 886-2-8261-8986 FAX : 886-2-8261-1885

www.hy1688.com.tw 236新北市土城區中央路二段191號10樓之5

SENSOR SWITCH

Item No.	RBS3302 系列	Description	ROLL BALL SWITCH	Version	8
Page	14 of 16	Date		Nov. 12, 2013	

(圖 5)

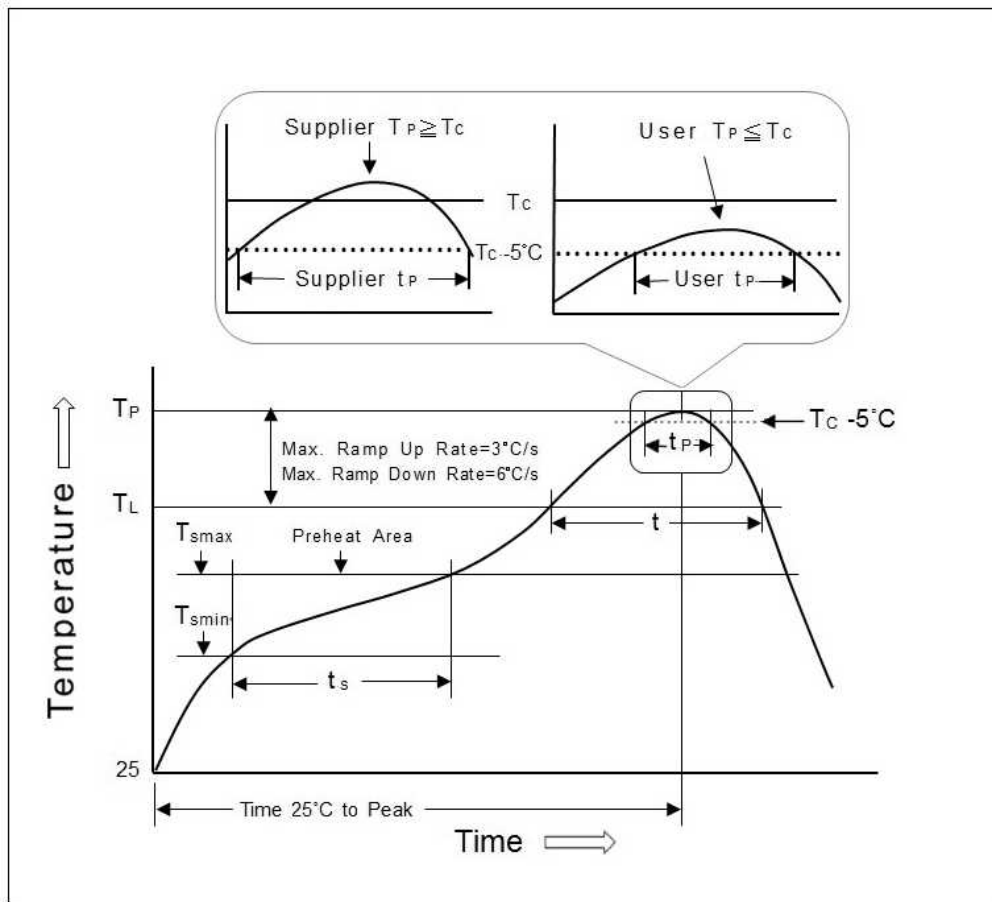



淮洋有限公司 HUI YANG CO., LTD.

TEL : 886-2-8261-8986 FAX : 886-2-8261-1885

www.hy1688.com.tw 236新北市土城區中央路二段191號10樓之5

SENSOR SWITCH

Item No.	RBS3302 系列	Description	ROLL BALL SWITCH	Version	8
Page	15 of 16		Date	Nov. 12, 2013	

● 包裝

	料 號	包 裝	數 量	總 數	尺寸(mm)
1.	RBS330210T	料帶	250 pcs	250 pcs	直徑=300 ; 寬=29
	RBS330211T	內箱	2 Reels	500 pcs	360 x 340 x 70
	RBS330212T				
	RBS330213T	外箱	10 內箱	5,000 pcs	70 0x 360 x 380

※ 包裝流程如下：產品圖片僅供參考！



料帶



內箱



外箱





淮 洋 有 限 公 司 HUI YANG CO.,LTD.

TEL : 886-2-8261-8986 FAX : 886-2-8261-1885

www.hy1688.com.tw 236新北市土城區中央路二段191號10樓之5

SENSOR SWITCH

Item No.	RBS3302 系列	Description	ROLL BALL SWITCH	Version	8
Page	16 of 16		Date	Nov. 12, 2013	

● 備註

1. 使用建議：使用於具震動場合時，建議加上 on delay 的設計；若震動過大時，建議選用光電式產品。
2. 由於公司政策是不斷的改善產品品質，因此規格書可能在沒有知會的情況下變更或修改，您可以透過本公司的業務人員取得最新資訊。在一般情況下，本公司所有產品都是依照規格書的標準條件生產。

● 注意事項

1. 如果該產品要用於其它具有更高安全性及可靠性的耐久設備中 (如生命維持裝置、宇宙航空裝置、防災及安全性裝置) 時，請確認是否合用，或者問我方瞭解詳細情況。
2. 焊接流程完成後，請勿使用溶劑或類似物品清洗開關。
3. 使用水溶性助焊劑可能導致開關破損。
4. 當焊接溫度超過規格書規範時，開關可能會分離。
5. 不要將開關用於高濕或有沾濕可能性的環境中，因這樣的環境可能會引起端子間之漏電流。
6. 超過額定負荷使用時，有發生火災的可能性，故請勿超過負荷使用。
7. 於電路中不得靠近或與強磁元件焊點直接接通(例如:繼電器、變壓器..等)。
8. 為預防 IR、PT 受損，請做靜電防護處理，例如：製程中使用導電腕帶或防靜電手套、設施機台做接地處理等。

