

# RoHS Compliance

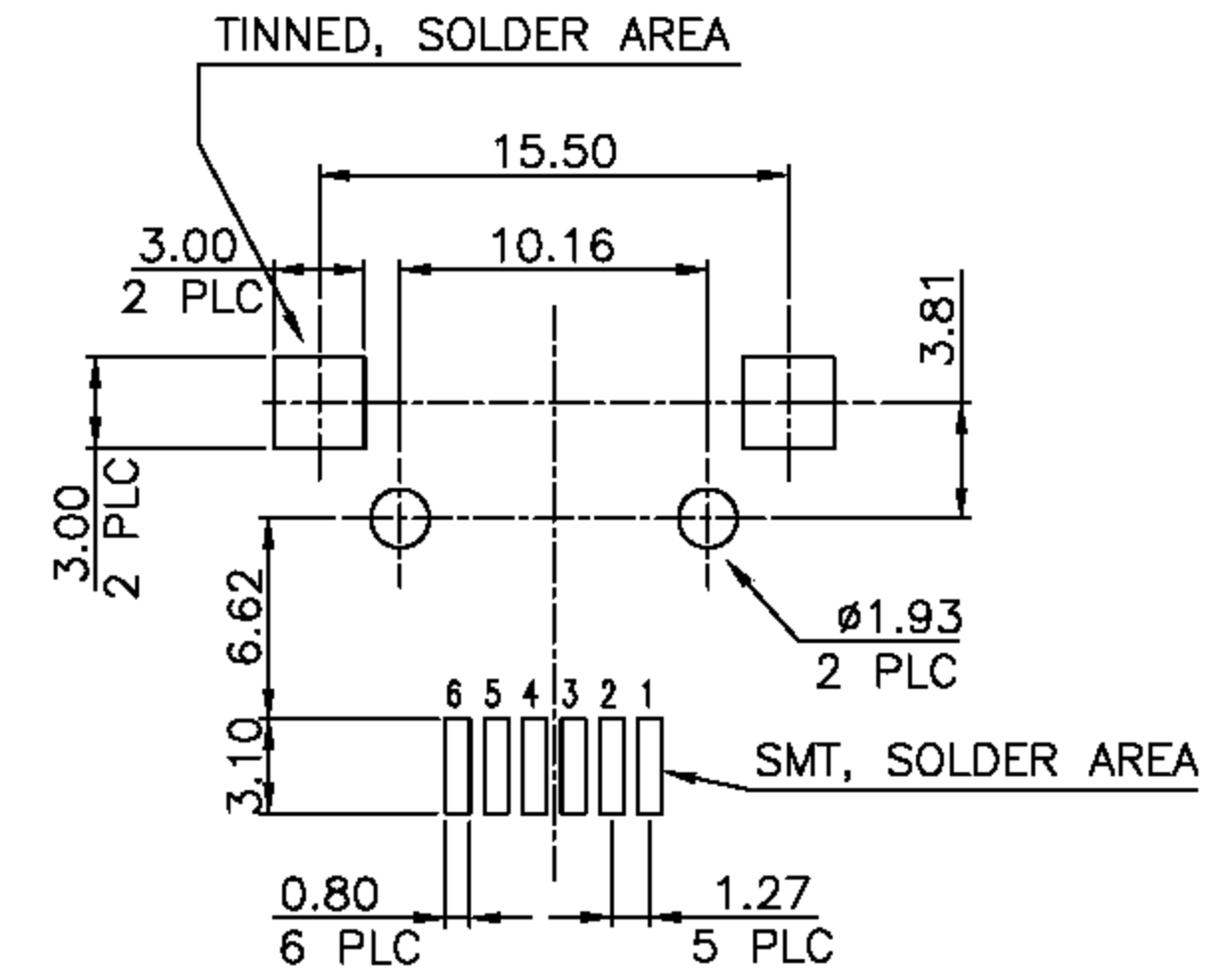
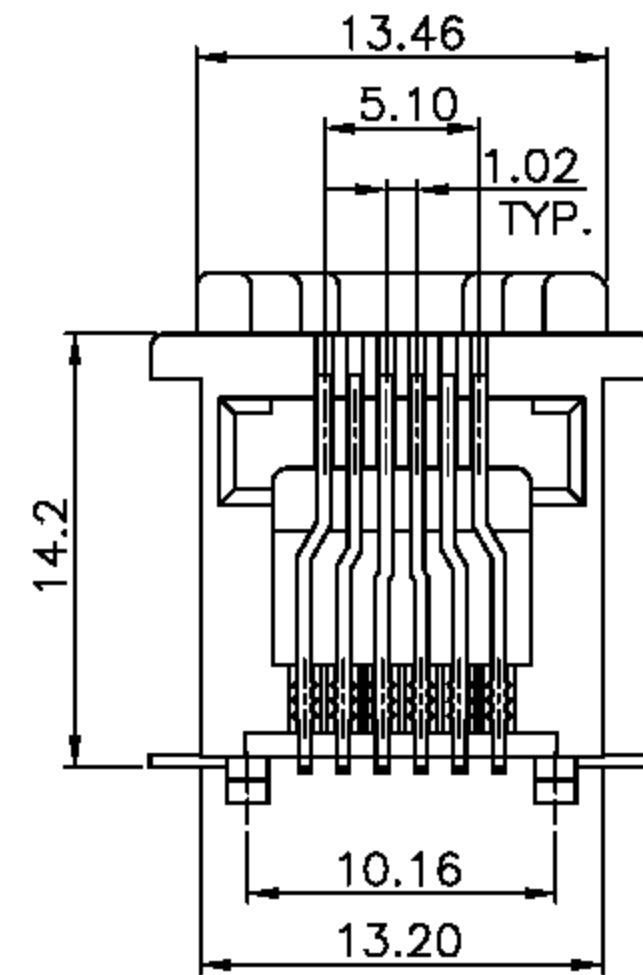
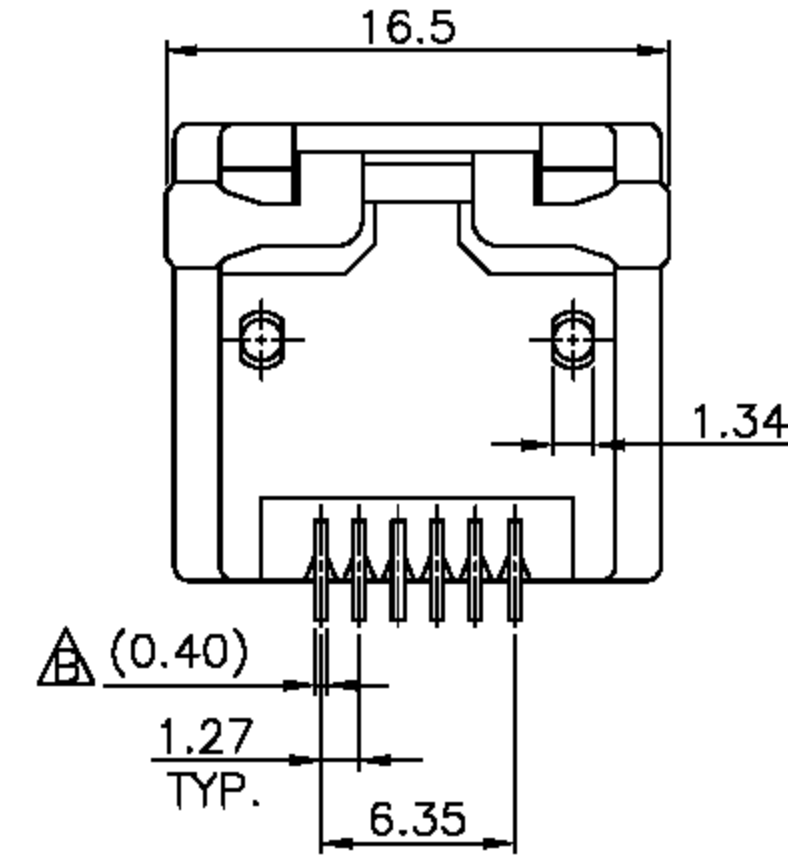
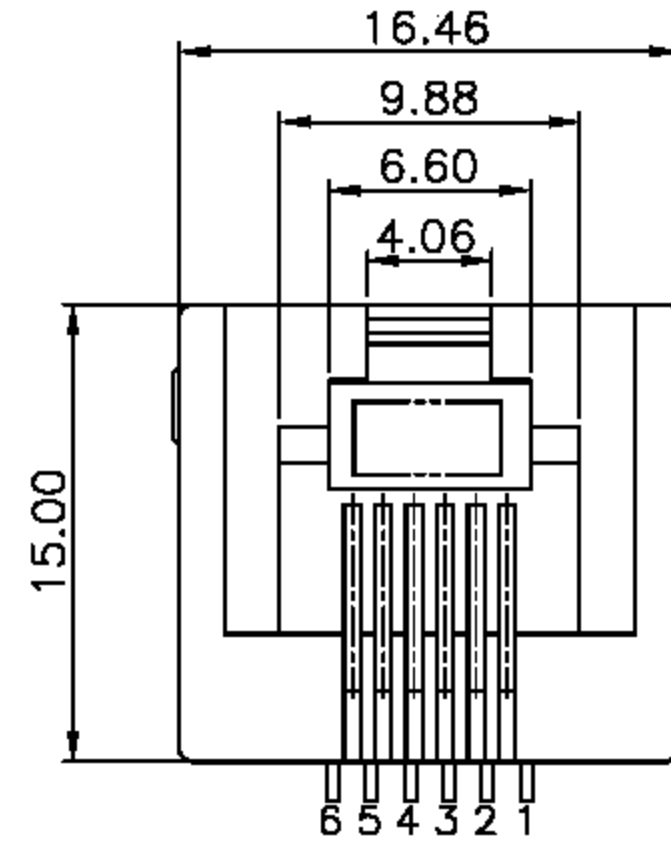
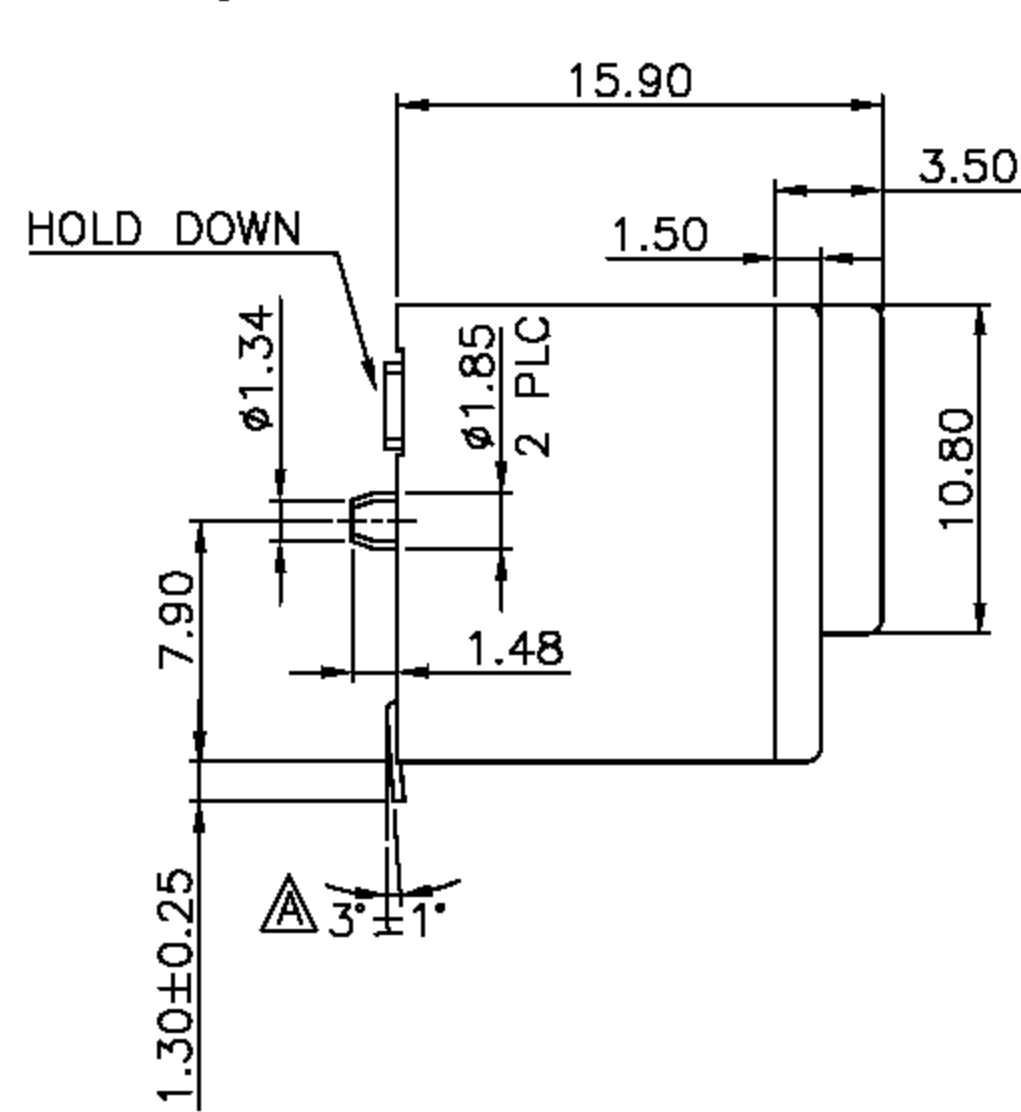

PCB LAYOUT

| REVISIONS |                         |           |       |
|-----------|-------------------------|-----------|-------|
| LTR       | DESCRIPTION             | DATE      | APP   |
| △         | 86°~90°                 | 12/31/'99 | CHANG |
| △         | 89°~91°                 | 03/09/'00 | CHANG |
| △         | 88°~90°<br>87°~89° Ref. | 03/31/'00 | CHANG |
| △         |                         | 11/14/'06 | CHANG |

|                        |                                   |                                       |   |                            |                    |
|------------------------|-----------------------------------|---------------------------------------|---|----------------------------|--------------------|
| DO NOT SCALE DRAWING   | TOLERANCES UNLESS OTHERWISE NOTED | INCH                                  | MM  | DR.<br><i>C.IAN.CI.LUO</i> | DATE<br>DEC-24 '08 |
| THIRD ANGLE PROJECTION | LINEAR<br>MM<br>INCH              | 00 ± .01<br>000 ± .005<br>0000 ± .002 | 0.0 ± 0.25<br>0.00 ± 0.13<br>0.000 ± 0.05 | CK'D<br><i>M.CHANG</i>     | DEC-24 '08         |
| MM<br>INCH             | ANGLE ± 0° 30'                    | RADII                                 | ± 0.40<br>- 0.15                          | APP'D<br><i>W.J.YANG</i>   | DEC-25 '08         |

|  |      |         |      |       |  |
|--|------|---------|------|-------|--|
| 淮洋有限公司 HUI YANG CO., LTD.<br>TEL : 886-2-8261-8986 FAX : 886-2-8261-1885<br>www.hy1688.com.tw 236 新北市土城區中央路二段191號10樓之5 |      |         |      |       |  |
| TITLE RJ11, TOP ENTRY JACK SMT TYPE  |      |         |      |       |  |
| SCALE  | SIZE | DWG.NO. | REV. | SHEET |  |
|  |      | 973903  | 7    | 1     |  |