

VW1 Series 《Water Proof Switches》

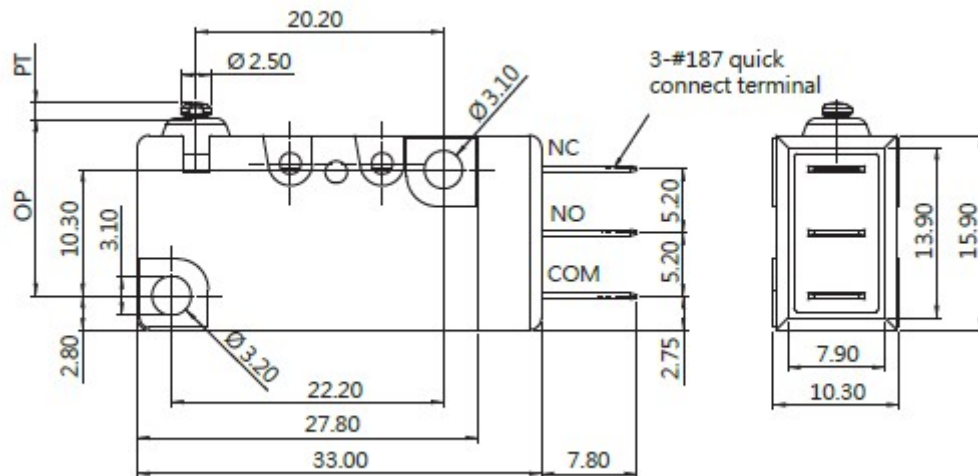

Specifications :

Ratings : 10A 125 / 250VA

Dimension : Unless otherwise specified, a tolerance of ± 0.4 mm applies to all dimensions.

Operating Frequency (mechanical).....120 operations / min

Operating Frequency (electrical).....10~30 operations / min

Contact Resistance (initial).....300m Ω (Max.)

Insulation Resistance (at 500VDC).....100M Ω (Min.)

Dielectric Strength (50-60Hz).....1500VAC RMS

Service Life (mechanical).....Min. 10000000 operations

Service Life (electrical).....6A~10A-Min. 10000 operations

Application :

Alarm devices, Home security, Time recorder, Air conditioner, Food processor, Juice maker, Grass trimmers, Mixer, Central water heating, Industrial apparatus, Special forklifts, Special vehicles

Contact Configuration :



Operating Characteristics :

SWITCH TYPE	PART SUFFIX	OF Max. (gf)		OP (mm)	PT Max. (mm)	OT Min. (mm)	MD Max. (mm)
		H	S				
VW1-□□□ 0-00D3-Z		H	300	14.7±0.4	1.2	1.0	0.4
		S	200				
		L	150				
		J	100				
VW1-□□□ 1-01D3-Z		H	255	15.1±0.6	2.6	1.1	0.6
		S	160				
		L	125				
		J	85				
VW1-□□□ 2-01D3-Z		H	-	15.0±1.1	5.1	1.2	1.1
		S	-				
		L	90				
		J	-				
VW1-□□□ 1-02D3-Z		H	160	14.8±0.8	4.0	1.5	0.9
		S	110				
		L	85				
		J	60				
VW1-□□□ 1-03D3-Z		H	100	12.4±2.0	7.0	-	2.5
		S	70				
		L	55				
		J	40				
VW1-□□□ 1-04D3-Z		H	-	18.1±0.8	3.6	1.7	1.0
		S	125				
		L	-				
		J	-				
VW1-□□□ 2-04D3-Z		H	-	16.7±1.5	7.2	2.1	1.7
		S	75				
		L	-				
		J	-				
VW1-□□□ 1-05D3-Z		H	-	20.6±0.5	2.1	1.0	0.5
		S	200				
		L	-				
		J	-				
VW1-□□□ 1-06D3-Z		H	195	20.4±0.7	3.3	1.3	0.7
		S	130				
		L	-				
		J	70				
VW1-□□□ 2-06D3-Z		H	105	20.2±1.2	6.5	1.5	1.4
		S	70				
		L	-				
		J	-				

* There is another series of VW1 with MD reduced to 63%.
* There is another series of VW1 with MD reduced to 63%.

Ordering Information :

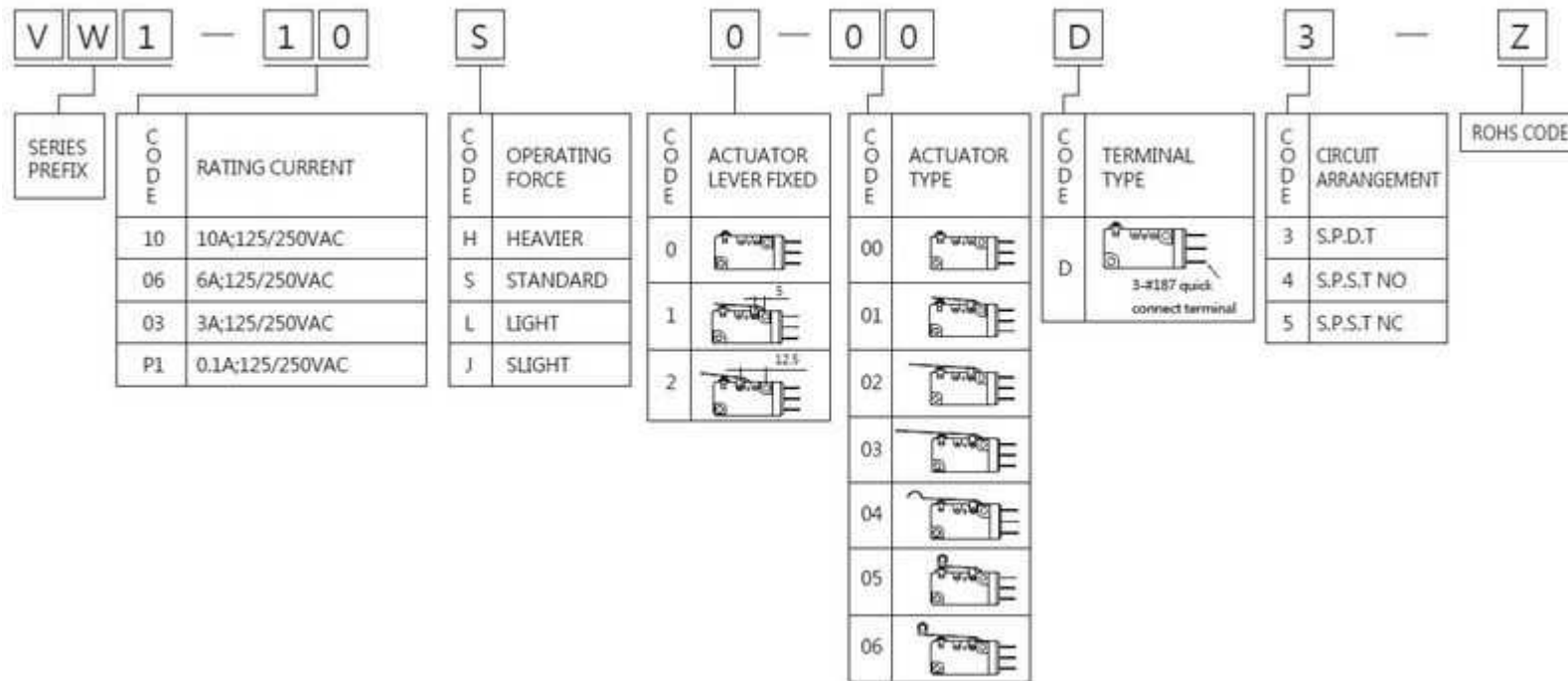

Terminal Types :

Quick Connect Terminal
187 Series D TYPE

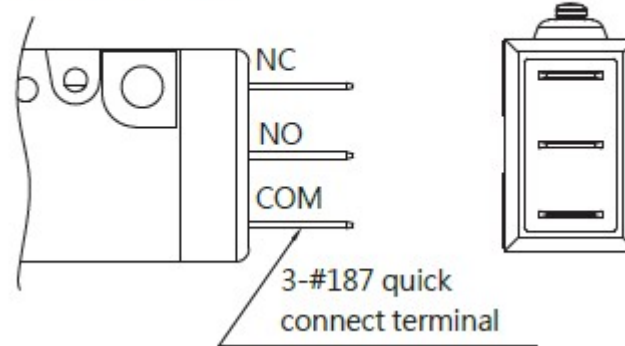

Mounting Holes :

2- \varnothing 3.1 mounting holes or M3 screw holes

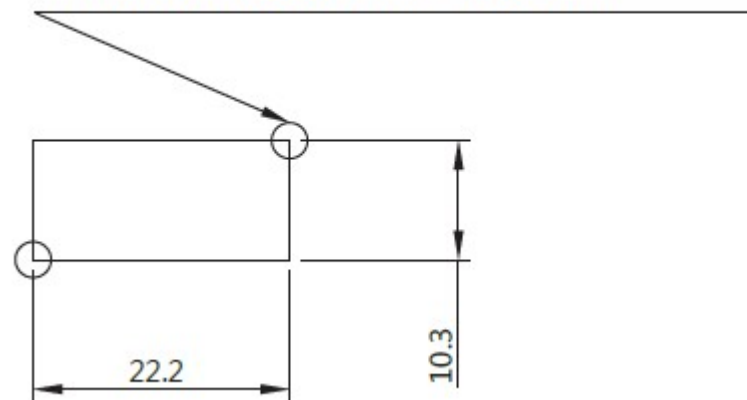

The Selection of Rating & Force :

MODEL	Rating	J	L	S	H
VW1	0.1A	*	*	*	*
	3A	*	*	*	*
	6 A	*	*	*	*
	10 A			*	*

NOTE : The Symbol " * " to represent the result is accepted