

Note:

1. Unless otherwise specified dimensions are in mm tolerance

Decimals angular
 $X \pm 0.2$ $\pm 2^\circ$
 $XX \pm 0.04$

2. Do not scale drawing

3. Time-current characteristics See Table 1

4. Fuse-link colour coding See Table 2

5. Meets SAE J2077/ISO 8820-3

Table 1—Time-Current Characteristics

Test Current	Opening Time	
	Min.	Max.
110%	100hrs.	---
135%	0.75s	600s
160%	0.25s	50s
200%	0.15s	5s
350%	0.04s	0.5s
600%	0.02s	0.1s

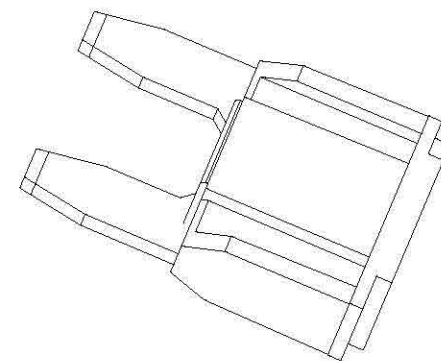
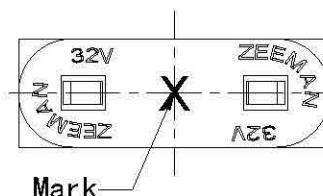
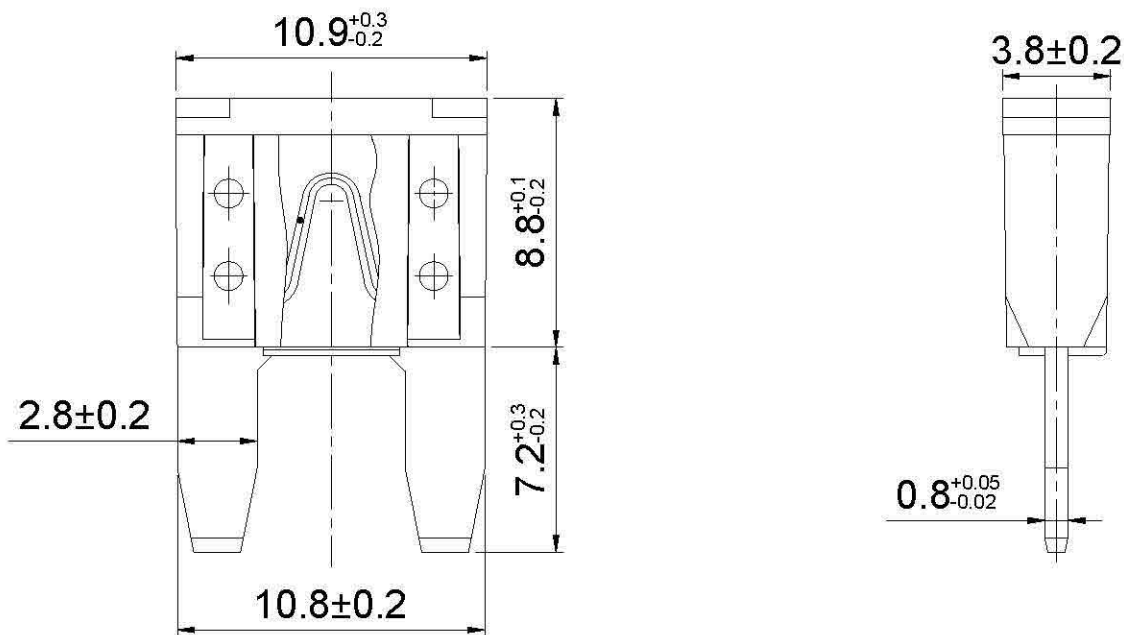

Table 2—Fuse-link colour coding

ITEM & AMP.	COLOR	ITEM & AMP.	COLOR
ATN 2 A	Gray	ATN 10 A	Red
ATN 3 A	Violet	ATN 15 A	Blue
ATN 4 A	Pink	ATN 20 A	Yellow
ATN 5 A	Tan	ATN 25 A	Clear
ATN 7.5 A	Brown	ATN 30 A	Green

- MATERIALS :1、ZINC ALLOY STRIP.
2、PA
- VOLTAGE RATING : 58 V DC
- This product meets the ROHS standard
- My company already got ISO/TS 16949 certificate

	TITLE	DRAWN BY	CHI	
	SCALE	MINI PLUG-IN FUSES	CHECKED BY	JU
	P/N	PART NO. ATN(GA1)	DESIGNED BY	JEAN
	REV		DATE	14/05/15