

R7 SERIES

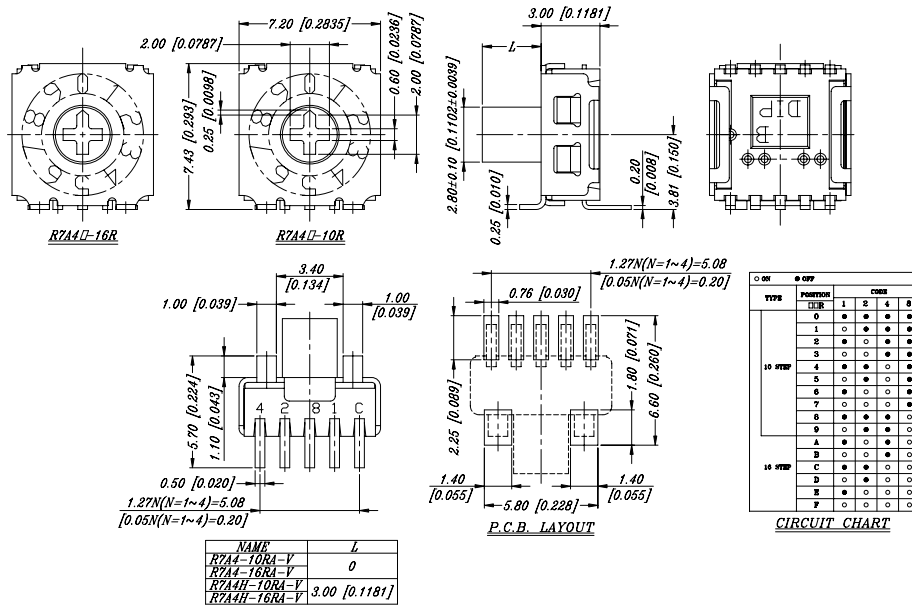

DIMENSION

R7A4-RA



General Tolerance : ±0.2mm

R7H3-RA

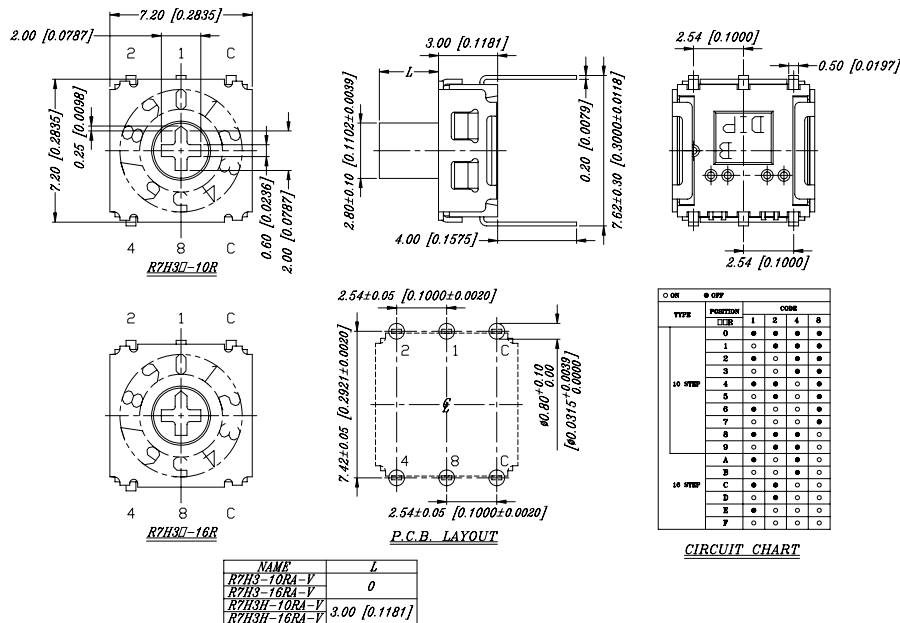

General Tolerance : ±0.2mm

R7H4-RA

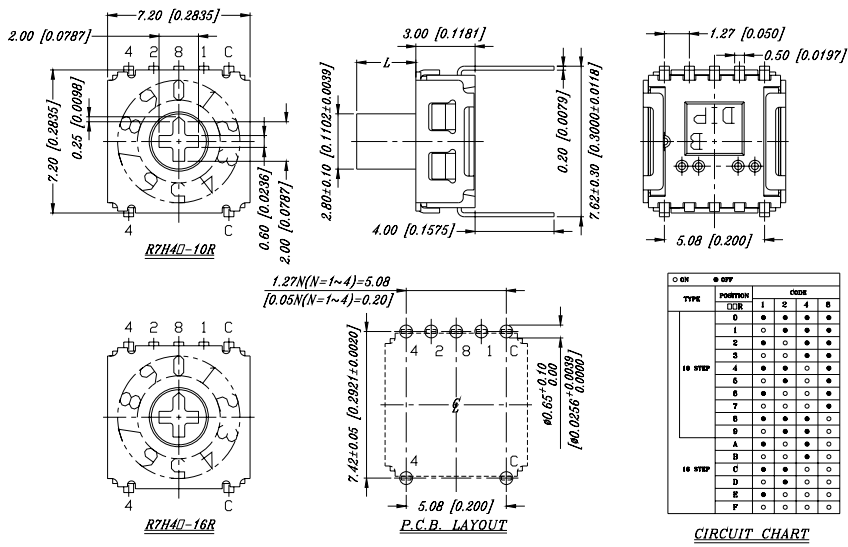

NAME	L
R7H4-10RA-V	0
R7H4-16RA-V	0
R7H4I-10RA-V	3.00 [0.1181]
R7H4I-16RA-V	3.00 [0.1181]

General Tolerance : ±0.2mm

R7M3-RA

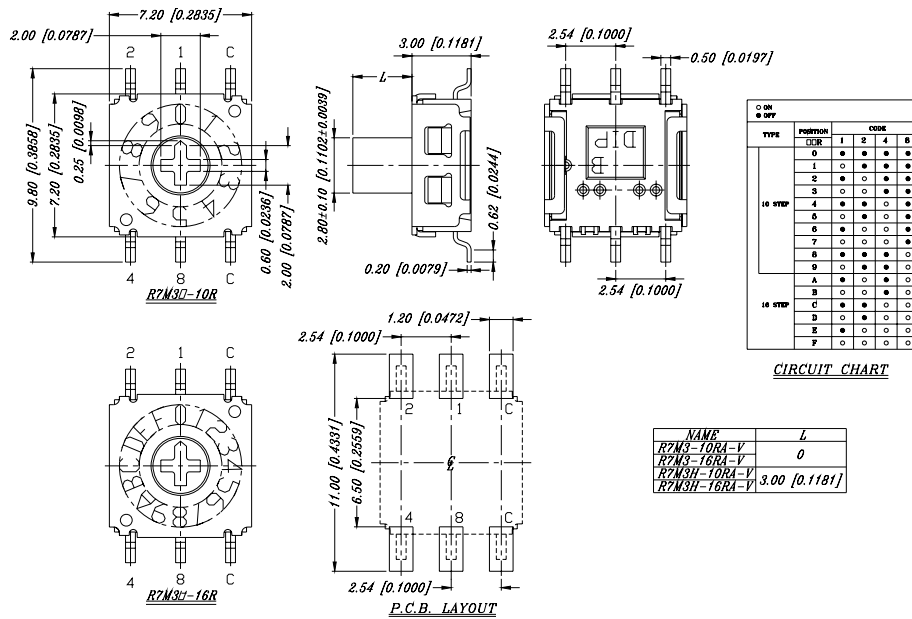

NAME	L
R7M3-10RA-V	0
R7M3-16RA-V	0
R7M3I-10RA-V	3.00 [0.1181]
R7M3I-16RA-V	3.00 [0.1181]

General Tolerance : ±0.2mm

R7M3-RAG

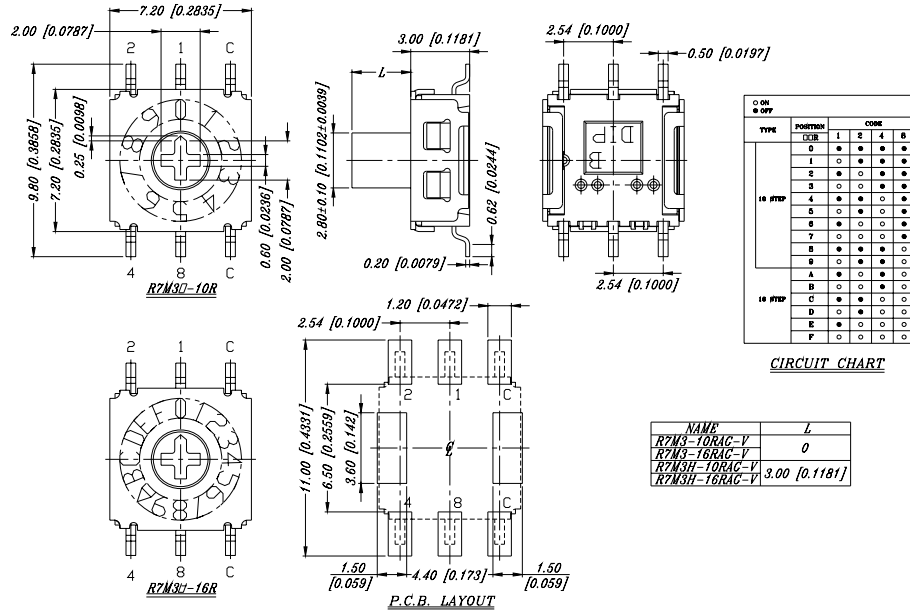

General Tolerance : ±0.2mm

R7M4-RA

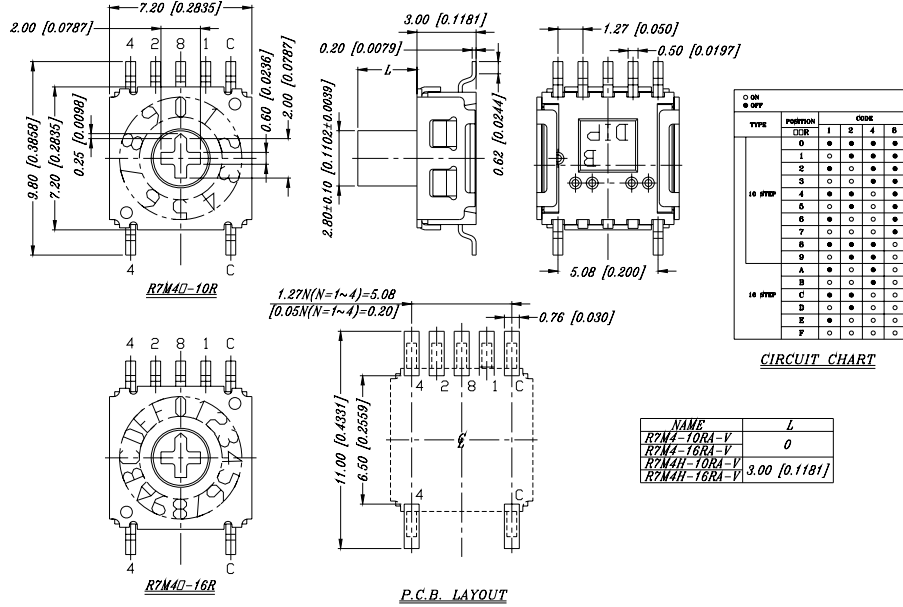

General Tolerance : ±0.2mm

R7M4-RAG

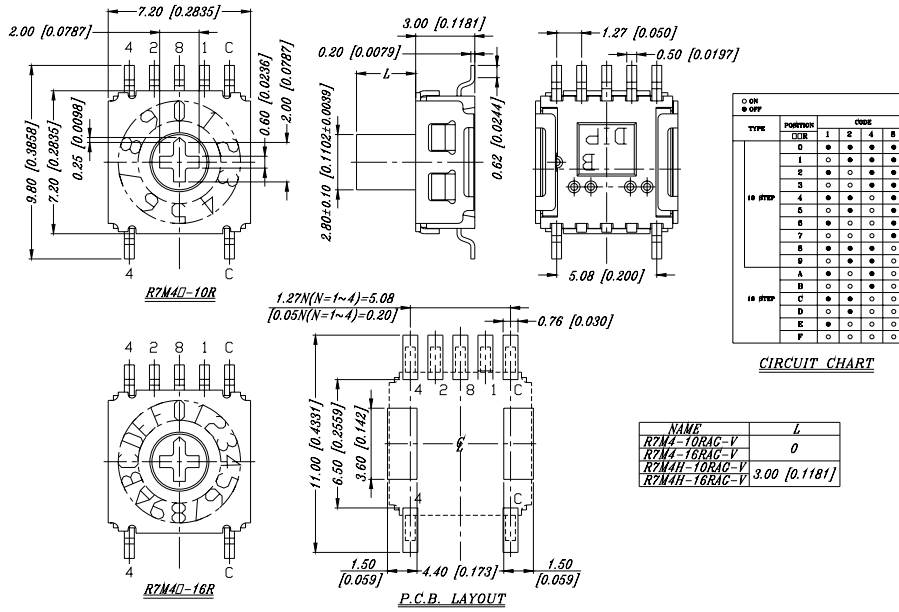

General Tolerance : ±0.2mm

R7V3-RA

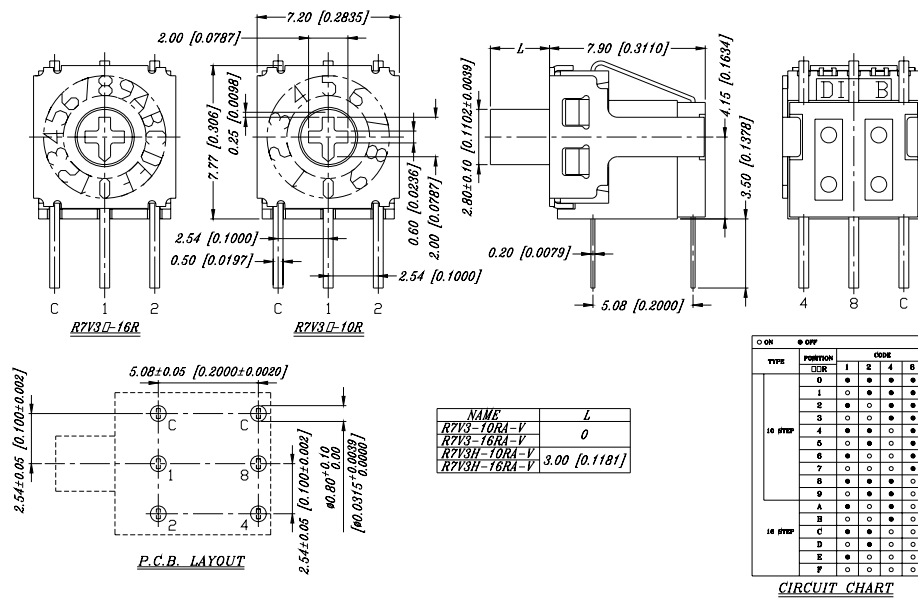

General Tolerance : ±0.2mm

R7V4-RA

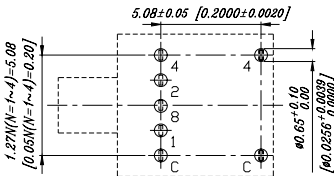
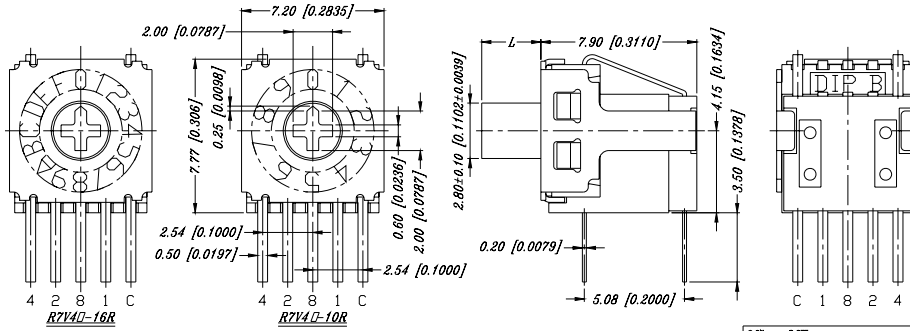

NAMP	L
R7V4-10RA-V	0
R7V4-16RA-V	0
R7V4H-10RA-V	3.00 [0.1181]
R7V4H-16RA-V	3.00 [0.1181]

TYPE	POSITION	CODE			
		1	2	4	8
16 STEP	0	●	●	●	●
	1	○	●	●	●
	2	○	○	●	●
	3	○	○	○	●
	4	●	○	○	○
	5	○	○	○	○
	6	○	○	○	○
	7	○	○	○	○
10 STEP	8	●	○	○	○
	9	○	○	○	○
	A	●	○	○	○
	B	○	○	○	○
	C	○	○	○	○
	D	○	○	○	○
	E	○	○	○	○
	F	○	○	○	○

CIRCUIT CHART

General Tolerance : ±0.2mm

HOW TO ORDER

R 7 - R - V -

- Package :
B = Tube
T/R = Tape & Reel
- Soldering :
V = Lead Free Solderable
- = Without Ground Terminal
G = With Ground Terminal (S.M.T Only)
- A = Flat-head Actuator
B = Cross-head Actuator
- R = Real Codes.
- Number Of Steps :
10 = 10 Steps
16 = 16 Steps
- Actuator Type :
 = Recessed Actuator
H = High Actuator (3.0mm)
- Number Of Terminals :
3 = 3x3
4 = 4x1
- Termination Type :
M = S.M.T
H = Through Hole
V = Right Angle
A = S.M.T Right Angle(4x1 Only)
- Rotary Type 7x7

SPECIFICATION

△MECHANICAL

Mechanical Life : 10,000 Steps
Operation Force : 200gf-cm max

△ENVIRONMENTAL

Operation Temperature Range : -30°C to +80°C
Storage Temperature Range : -40°C to +90°C

△ELECTRICAL

Electrical Life: 10,000 Steps
Switching Rating: 50 mA, 12 VDC

MATERIAL

△COVER : Nickel silver
△SEAL-1 : Silicone rubber
Color : Black, Square
△SEAL-2 : Silicone rubber
Color : Black, Round
△ACTUATOR : PA9T High-temp Thermoplastic
Color : Red
△BLOCK : Stainless steel
△CONTACT : Alloy copper
△SPRING PLATE : Piano wire
△BASE : PA9T High-temp Thermoplastic
Color : Black
△TERMINAL : Brass with gold plated

SOLDERING PROCESS

△HAND SOLDERING : Us a soldering iron of 30 watts, controlled at 350°C approximately 5 seconds while applying solder.

△REFLOW SOLDERING : When applying reflow soldering, the peak temperature or the reflow over should be set to 260°C max.

△Temperature Profile :

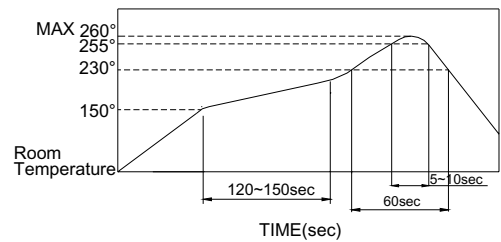

PACKING