

Technical Data Sheet- Light Transmitting Unit

DATA LINK : DLT15M1

Features

- High speed signal transmission (16Mbps, NRZ signal)
- Input TTL compatible
- +3~+5V power source

Descriptions

The light transmitting unit is a standard-package product with connector and opto-electric component packaged with LED and drive IC. The function of unit changes the electric signal into light signal and be transmitted by plastic fiber.

The unit is operated at single+3V~ +5V and the input signal is TTL compatible. The DLT15M1 has a maximum operating speed of 16 Mbps. The light signal is coupled into plastic fiber by connector. The unit has high performance at low dissipation current, steady light output and efficient light coupling.

Applications

- Audio equipment
- DVD player
- PC, Notebook
- Sound card

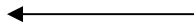
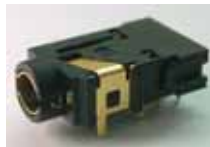

Device Selection Guide

Chip		Operating Voltage (Vcc)	Dissipation Current(mA)	Fiber Coupling Light Output (dBm)		
IC Material	LED p(nm)			Min.	Typ.	Max.
Si	650	2.7~5.5	5.5	-21	-	-15

Technical Data Sheet- Light Transmitting Unit

DATA LINK : DLT15M1

Package Dimensions

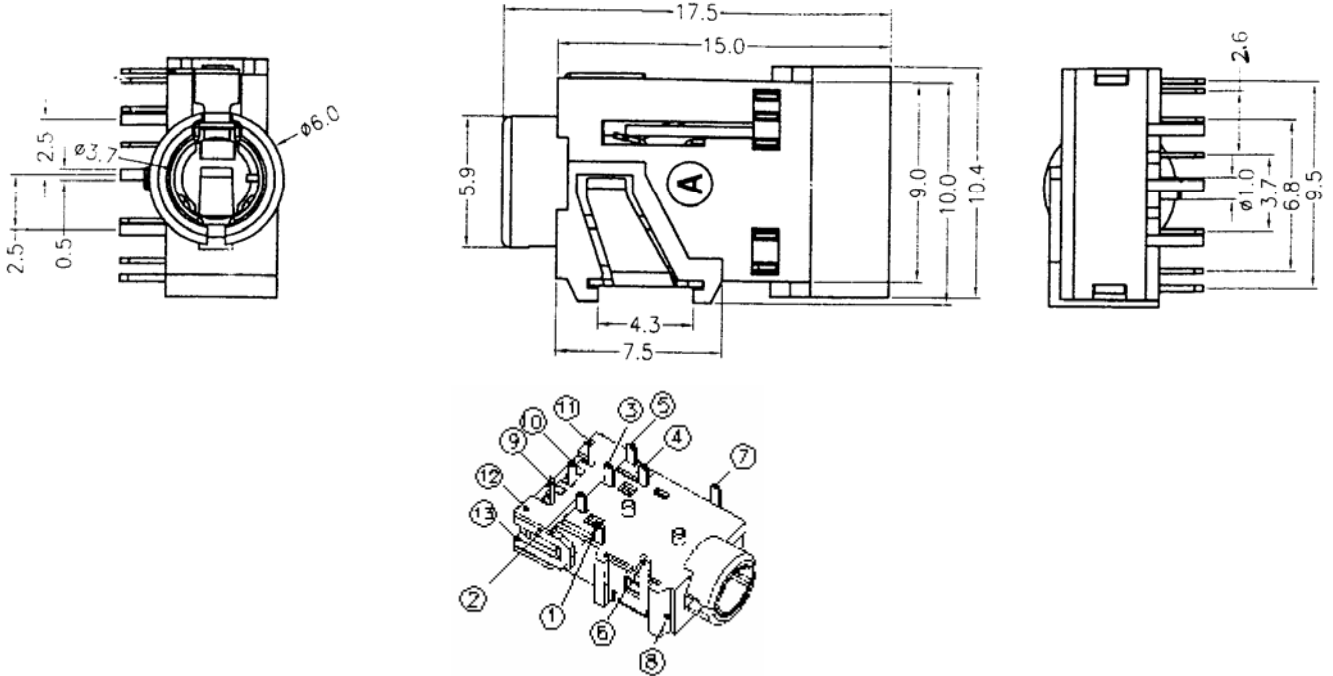

- Notes:**
1. All dimensions are in millimeters.
 2. General Tolerance: ± 0.2 mm
 3. Pin 1 ~ 7 golden plating.

Pin Function

- 1 ~ 7 : jack terminal (1 : left channel ; 2;4 : detector ; 3 : right channel ; 5 : video ;
6 : stereo ; 7 : GND)
- 9 ~ 11 : device terminal (9 : GND ; 10 : Vcc ; 11 : Vin)

Jack Terminal Configuration

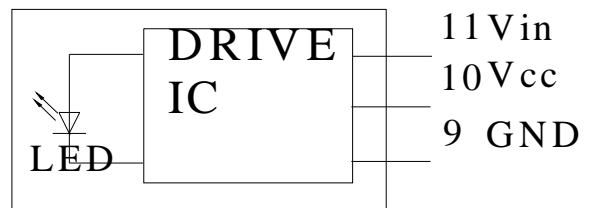
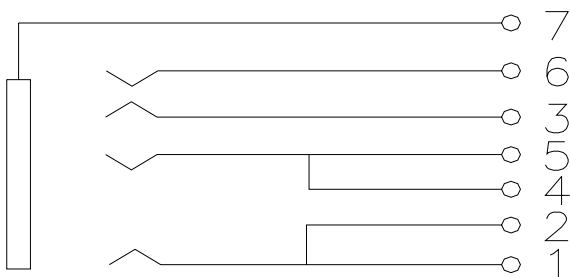

Technical Data Sheet- Light Transmitting Unit

DATA LINK : DLT15M1

Optical Mini-jack Connection (using JIS C6560 standard plug)

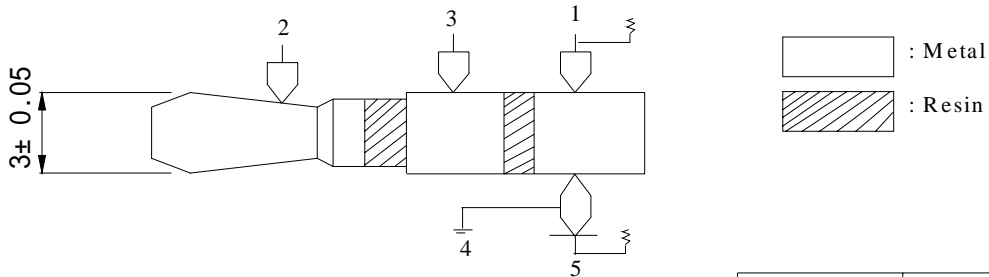

Analog electric signal

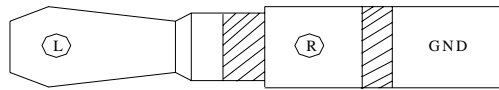

Digital optical signal

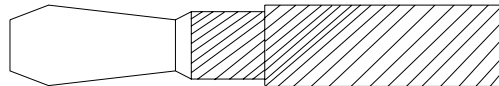

Input side	Output side
LINE IN MIC	LINE OUT HEAD PHONE
	OPTICAL DIGITAL OUTPUT

Type of plug	Output of terminal		Output of terminal
	5	1	2,3
Analog electricity	L	L	Signal data input/output
Digital optics	L	H	Signal data output
No plug	H	H	-

Absolute Maximum Ratings(Ta = 25)

Parameter	Symbol	Rating	Unit
Supply Voltage	Vcc	-0.5 to 7	V
DC Input Voltage	Vin	-0.5 to Vcc+0.5	V
Power Dissipation	P	120	mW
Storage Temperature	Tstg	-30 to 80	
Operating Temperature	Topr	-20 to 70	
Soldering Temperature	Tsol	260*	

*Soldering time ≤ 5s / 2 times.

Technical Data Sheet- Light Transmitting Unit

DATA LINK : DLT15M1

Mechanical Electro-Optical Characteristics (Jack)

Parameter	Symbol	Conditions	MIN.	TYP.	MAX.	Unit
Insertion and withdrawal force	Fp	*a	3.9	-	34.3	N
Contact resistance	Rcon	*b	-	-	30	m
Isolation resistance	Riso	D.C.500V, 1min	100	-	-	M

*a 4-pole plug (3.5) for test.

*b It measures at 100 mA or less 1000 Hz.

Electro-Optical Characteristics

Parameter	Symbol	Conditions	MIN.	TYP.	MAX.	Unit
Operating Voltage	Vcc	-	2.7	-	5.5	V
Peak Emission Wavelength	λ_p	-	640	-	670	nm
Transmission Speed		NRZ signal	0.1	-	16	Mbps
Transmission Distance		Using APF	0.2	-	20	m
Pulse Width Distortion	Δtw	16Mbps NRZ Signal	-25	-	25	ns
Fiber Coupling Light Output	Pf	*1	-21	-17	-15	dBm
Dissipation Current	Icc	*2	-	-	10	mA
High Level Input Voltage	V _{IH}		2	-	-	v
Low Level Input Voltage	V _{IL}		-	-	0.8	v
Rise Time	t _r	*3	-	30	40	ns
Fall Time	t _f	*3	-	20	30	ns
Low → High propagation delay time	t _{PLH}	*3	-	-	100	ns
High → Low propagation delay time	t _{PHL}	*3	-	-	100	ns
Jitter	Δt_j	*3	-	1.5	15	ns

The DLT15M1 light transmitting unit satisfies EIAJ CP-1201 digital audio interface standard.

Technical Data Sheet- Light Transmitting Unit

DATA LINK : DLT15M1

Reliability Test Items

No.	Item	Test Condition	Test Hour/Cycle	Samples	Number (n) Failure (c)
1	Soldering Heat	260 ±5	5 sec./2times	22	n=22, c=0
2	High temp. & Hum. storage	Ta=40 , 90%RH	500	22	n=22, c=0
3	High temp. storage	Ta=80	500	22	n=22, c=0
4	Low Temp. storage	Ta=-30	500	22	n=22, c=0
5	Temp. cycling	-30 ~ 80 (30min) (5min) (30min)	20	22	n=22, c=0
6	High Temp. Operation life	Ta=60 , Vcc=5V ON	500	22	n=22, c=0
7	Repeated operation	500 times	Coupling force < 2 kg 0.4kg<Detaching force <2kg	22	n=22, c=0
8	Terminal Strength(tension)	Weight: 500 g 30 sec./each terminal		22	n=22, c=0
9	Terminal Strength(bending)	Weight: 500 g 2 times/each terminal		22	n=22, c=0
10	Mechanical Shock	Acceleration: 1000m/s ² Pulse width: 6 ms 3 times/ X,Y,Z direction		22	n=22, c=0
11	Vibration	Frequency range: 10~55 Hz /sweep 1 min Overallamplitude:1.5 mm 2H./X,Y,Z direction		22	n=22, c=0

I_{cc} (dissipation current): CURRENT ATTENUATE DIFFERENCE < 20%

P_f (fiber coupling light output): BRIGHTNESS ATTENUATE DIFFERENCE < 20%

T_{PLH} (propagation L → H delay time): DELAY TIME DIFFERENCE < 20%

T_{PHL} (propagation H → L delay time): DELAY TIME DIFFERENCE < 20%

T_r (rise time): TIME DIFFERENCE < 20%

T_f (fall time): TIME DIFFERENCE < 20%

Technical Data Sheet- Light Transmitting Unit

DATA LINK : DLT15M1

Measuring Method

*1 Measuring method of optical output coupling fiber

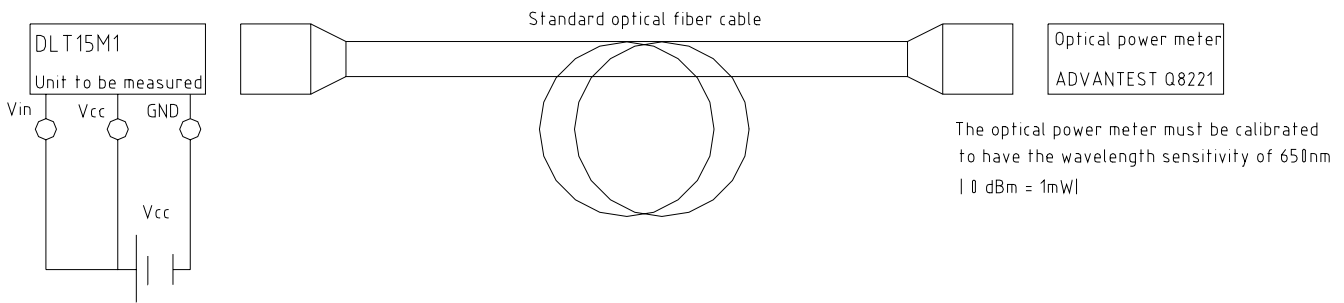

* 2 Input voltage/power dissipation measuring method

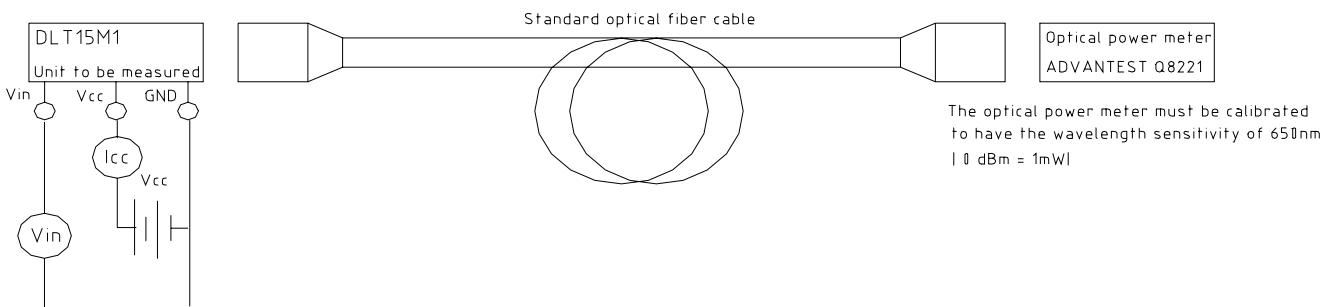

*3 Pulse response and jitter measuring method

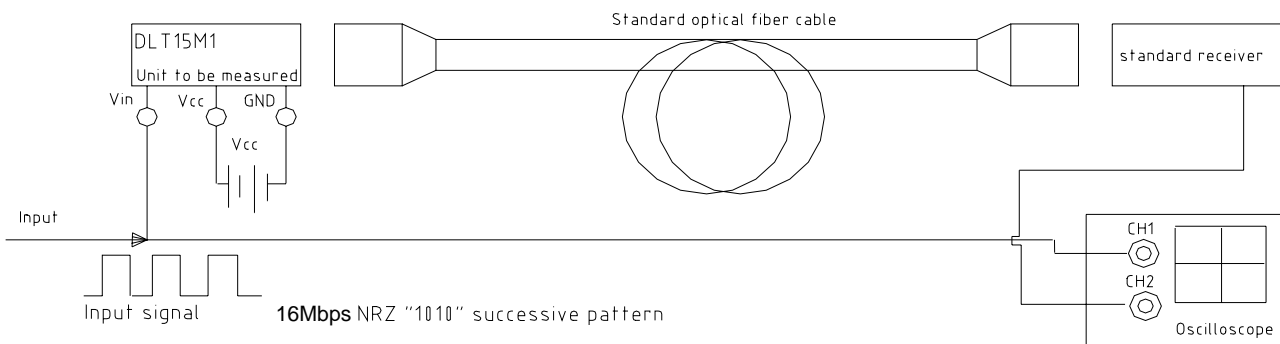

Technical Data Sheet- Light Transmitting Unit

DATA LINK : DLT15M1

PCB Layout For Electrical Circuit

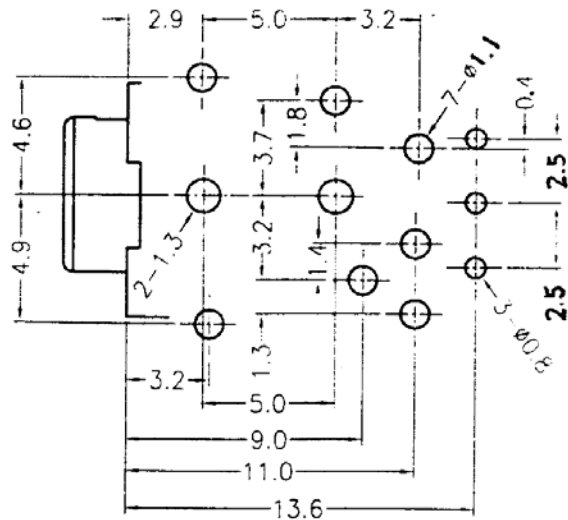

Notes:

1. unit:mm
2. Unspecified tolerance: $\pm 0.3\text{mm}$
3. Substrate Thickness:1.6mm

Precautions for Using Method

1. Connect a by-pass capacitor (0.1uF) close to the DLT15M1 within 7 mm of the unit lead frame.
2. Take proper electrostatic-discharge (ESD) precautions while handling these devices. These devices are sensitive to ESD.
3. IR-reflow Maximum ratings

IR-reflow time	Peak Temp.	Over 200 time
400 sec	240	150 sec

Technical Data Sheet- Light Transmitting Unit

DATA LINK : DLT15M1

Material Description

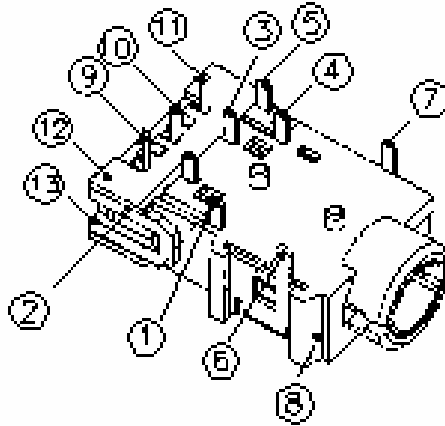

ITEM	NAME	MATERIAL	FINISH	NOTE
1	Left channel	STEEL	Au	
2	Detector	BRONZE	Au	
3	Right channel	PBS	Au	
4	Detector	BRONZE	Au	
5	Video	PBS	Au	
6	Stereo	PBS	Au	
7	GND	PBS	Au	
8	Housing	PA		
9	GND	PBS	Ag	
10	Vcc	PBS	Ag	
11	Vin	PBS	Ag	
12	Switch Housing	PA		
13	Cover	PA		

Technical Data Sheet- Light Transmitting Unit

DATA LINK : DLT15M1

Package

Item	Quantity	Total	Size (long*width*high)
Tray	1	150 pcs	28.5*28.5*1.08 cm
Inner box	10 tray/box	1500 pcs	29*29*14cm
Outer box	2 inner box/outer box	3000 pcs	60*31*17.8 cm

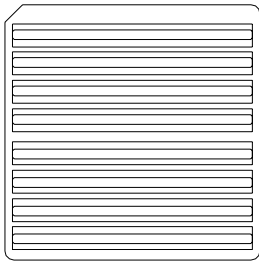

150 pcs/tray
(28.5*28.5*1.08 cm)

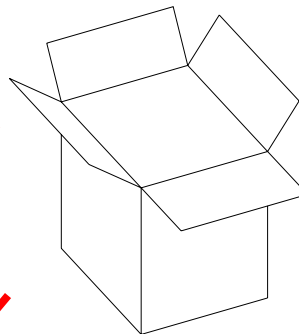
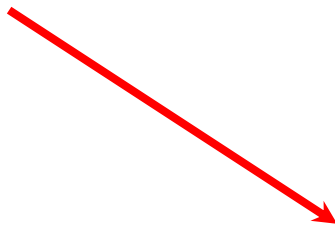

10 tray/box(1500pcs)
(29*29*14cm)

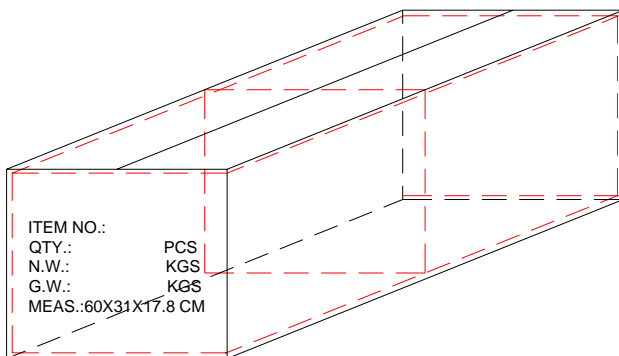
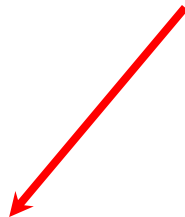

2 inner box/outer box (3000pcs)
(60*31*17.8cm)

Technical Data Sheet- Light Transmitting Unit
DATA LINK : DLT15M1

REV	DESCRIPTION	RELEASE DATE