

## Technical Data Sheet- Light Transmitting Unit

### TY LINK : DLT11R2-D2

#### Features

- High speed signal transmission ( 16Mbps, NRZ signal )
- Input TTL compatible
- +3~+5V power source

#### Descriptions

The TYLINK is a new design connector including traditional RCA and Data Link inner opto-electric component. Not only does TYLINK transmit electric digital signal but also light signal.

The optic unit is operated at single +3V~ +5V and RCA input signal at  $\pm 0.5$  V. The DLT11R2-D2 has a maximum operating speed of 16 Mbps. The optic unit has high performance at low dissipation current, steady light output and efficient light coupling.

#### Applications

- DVD player



#### Device Selection Guide

Chip		Operating Voltage (Vcc)	Dissipation Current(mA)	Fiber Coupling Light Output (dBm)		
IC Material	LED p(nm)			Typ.	Min.	Typ.
Si	650	2.7~5.5	5.5	-21	-	-15

# Technical Data Sheet- Light Transmitting Unit

## TY LINK : DLT11R2-D2

### Package Dimensions

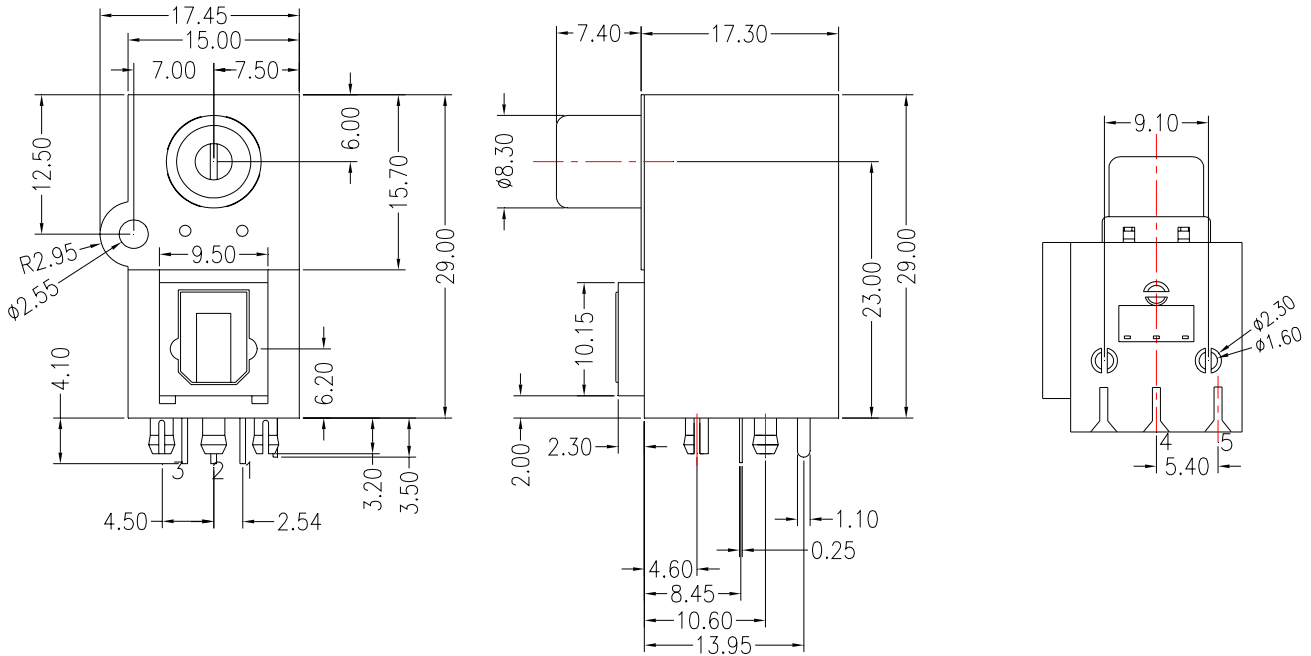

- Notes:** 1.All dimensions are in millimeters.  
2.General Tolerance:±0.2mm

### Pin Function

- |        |            |
|--------|------------|
| 1. GND | 4.Positive |
| 2. Vcc | 5.Negative |
| 3. Vin |            |

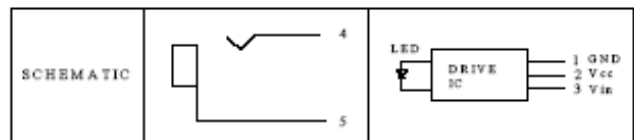

### Absolute Maximum Ratings( Ta = 25 )

Parameter	Symbol	Rating	Unit
Supply Voltage	Vcc	-0.5 to 7	V
DC Input Voltage	Vin	-0.5 to Vcc+0.5	V
Power Dissipation	P	120	mW
Storage Temperature	Tstg	-30 to 80	
Operating Temperature	Topr	-20 to 70	
Soldering Temperature	Tsol	260*	

\* Soldering time ≤ 5 s / 2 times.

# Technical Data Sheet- Light Transmitting Unit

## TY LINK : DLT11R2-D2

### Electro-Optical Characteristics

Parameter	Symbol	Conditions	MIN.	TYP.	MAX.	Unit
Operating Voltage(optic unit)	V <sub>cc</sub>	-	2.7	-	5.5	V
(electrical unit)			0.75		1.25	
Peak Emission Wavelength	$\lambda_p$	-	640	-	670	nm
Transmission Speed		NRZ signal	DC	-	16	Mbps
Transmission Distance		Using APF	0.2	-	20	m
Pulse Width Distortion	$\Delta tw$	16Mbps NRZ Signal	-25	-	25	ns
Fiber Coupling Light Output	P <sub>f</sub>	*1	-21	-17	-15	dBm
Dissipation Current	I <sub>cc</sub>	*2	-	5	10	mA
High Level Input Voltage	V <sub>IH</sub>		2	-	-	v
Low Level Input Voltage	V <sub>IL</sub>		-	-	0.8	v
Rise Time	t <sub>r</sub>	*3	-	30	40	ns
Fall Time	t <sub>f</sub>	*3	-	20	30	ns
Low → High propagation delay time	t <sub>PLH</sub>	*3	-	-	100	ns
High → Low propagation delay time	t <sub>PHL</sub>	*3	-	-	100	ns
Jitter (rise time)	$\Delta tr$	*3	-	1.5	15	ns
Jitter (fall time)	$\Delta tf$	*3	-	1.5	15	ns

The DLT11R2-D2 light transmitting unit satisfies EIAJ CP-1201 digital audio interface standard.

# Technical Data Sheet- Light Transmitting Unit

## TY LINK : DLT11R2-D2

### Reliability Test Items

No.	Item	Test Condition	Test Hour/Cycle	Samples	Number (n) Failure (c)
1	Soldering Heat	260 ±5	5 sec./2times	22	n=22, c=0
2	High temp. & Hum. storage	Ta=40 , 90%RH	500	22	n=22, c=0
3	High temp. storage	Ta=80	500	22	n=22, c=0
4	Low Temp. storage	Ta=-30	500	22	n=22, c=0
5	Temp. cycling	-30 ~ 80 (30min) (5min) (30min)	20	22	n=22, c=0
6	High Temp. Operation life	Ta=60 , Vcc=5V ON	500	22	n=22, c=0
7	Repeated operation	500 times	Coupling force < 2 kg 0.4kg<Detaching force <2kg	22	n=22, c=0
8	Terminal Strength(tension)	Weight: 500 g 30 sec./each terminal		22	n=22, c=0
9	Terminal Strength(bending)	Weight: 500 g 2 times/each terminal		22	n=22, c=0
10	Mechanical Shock	Acceleration: 1000m/s <sup>2</sup> Pulse width: 6 ms 3 times/ X,Y,Z direction		22	n=22, c=0
11	Vibration	Frequency range: 10~55 Hz /sweep 1 min Overallamplitude:1.5 mm 2H./X,Y,Z direction		22	n=22, c=0

I<sub>cc</sub> (dissipation current): CURRENT ATTENUATE DIFFERENCE < 20%

P<sub>f</sub> (fiber coupling light output): BRIGHTNESS ATTENUATE DIFFERENCE < 20%

T<sub>PLH</sub> (propagation L → H delay time): DELAY TIME DIFFERENCE < 20%

T<sub>PHL</sub> (propagation H → L delay time): DELAY TIME DIFFERENCE < 20%

T<sub>r</sub> (rise time): TIME DIFFERENCE < 20%

T<sub>f</sub> (fall time): TIME DIFFERENCE < 20%

# Technical Data Sheet- Light Transmitting Unit

## TY LINK : DLT11R2-D2

### Measuring Method

\*1 Measuring method of optical output coupling fiber

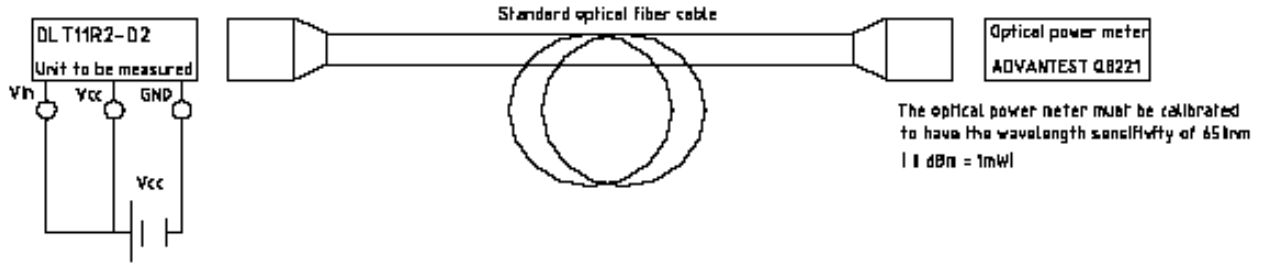

\*2 Input voltage/power dissipation measuring method

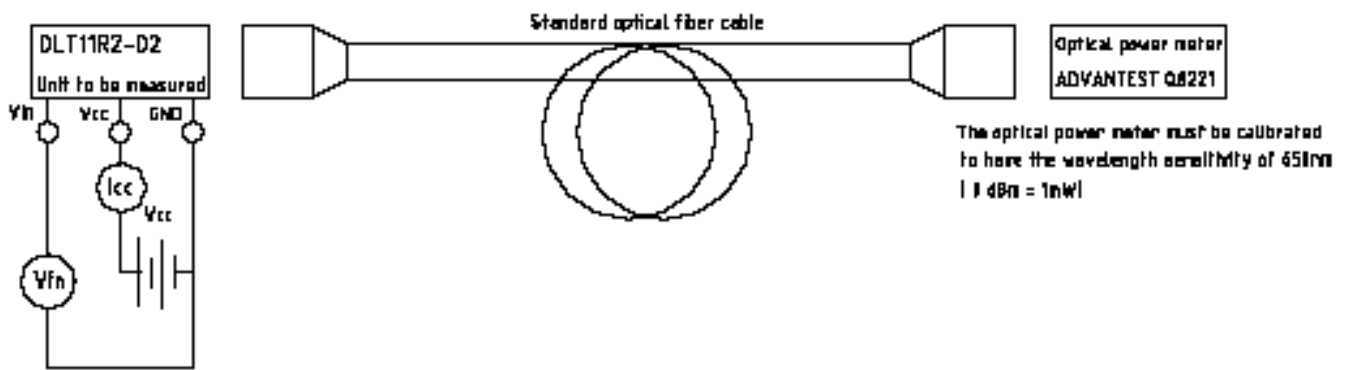

\*3 Pulse response and jitter measuring method

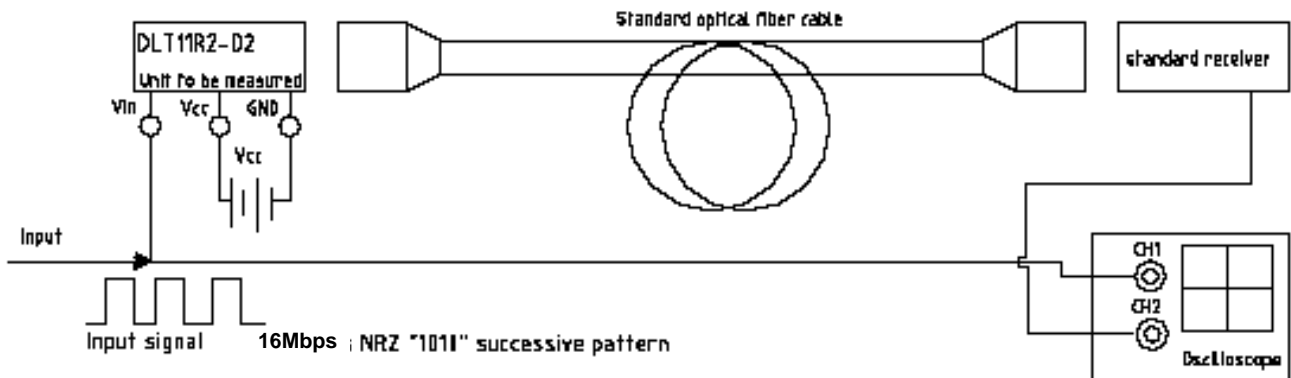

# Technical Data Sheet- Light Transmitting Unit

## TY LINK : DLT11R2-D2

### PCB Layout For Electrical Circuit

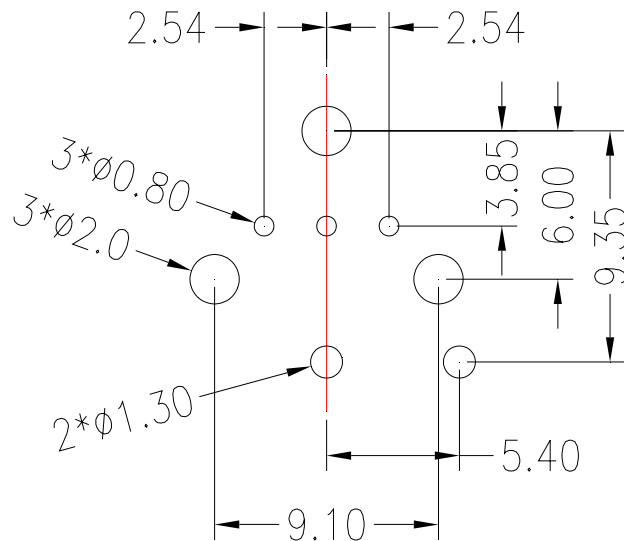

### Notes:

1. Unit:mm
2. Unspecified tolerance:  $\pm 0.3$ mm
3. Substrate Thickness:1.6mm

### Precautions for Using Method

1. Connect a by-pass capacitor (0.1uF) close to the DLT11R2-D2 within 7 mm of the unit lead frame between Vcc and GND.
2. Take proper electrostatic-discharge (ESD) precautions while handling these devices. These devices are sensitive to ESD.

# Technical Data Sheet- Light Transmitting Unit

## TY LINK : DLT11R2-D2

### Material Description

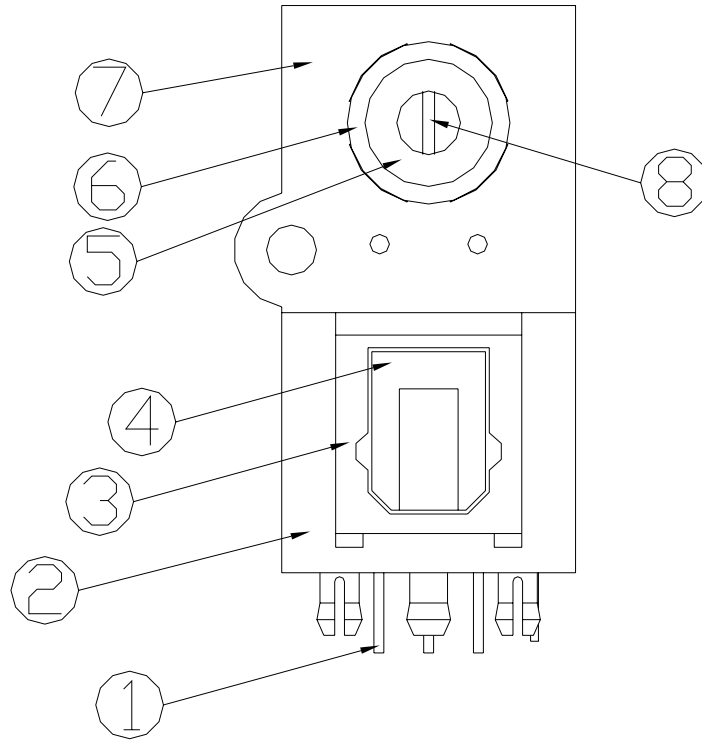

No.	Description	Material
1	OPTIC COMPONENT	
2	Housing	PA66
3	Set	PBT
4	Shutter	PC
5	Inner hole	PBT
6	Contact terminal (-)	PHOSPHOR BRONZE
7	Shield	PHOSPHOR BRONZE
8	Contact terminal (+)	PHOSPHOR BRONZE

# Technical Data Sheet- Light Transmitting Unit

## TY LINK : DLT11R2-D2

### Package

Item	Quantity	Total	Size ( long*width*high )
Tray	1	100 pcs	44.5*28.2*2.85cm
Outer box	10 tray/box	1000 pcs	46*29.5*30 cm



100 pcs/tray  
(44.5\*28.2\*2.85 cm)



10 tray/box(1000pcs)  
(46\*29.5\*30cm)



**Technical Data Sheet- Light Transmitting Unit**  
**TY LINK : DLT11R2-D2**

REV	DESCRIPTION	RELEASE DATE