

Technical Data Sheet- Light Receiving Unit DATA LINK : DLR11M1

Features

- High PD sensitivity for red light
- High speed up to 16 Mbps
- Low power consumption and current dissipation
- +3~+5V power source

Descriptions

The light receiving unit is a standard-package product with connector and opto-electric component packaged with PD and I/V amplifier IC. The function of unit changes the light signal into electric signal.

The unit is operated at +3~+5V and the input signal is TTL compatible. The DLR11M1 has a maximum operating speed of 16 Mbps.

Applications

- Audio equipment
- DVD player
- PC, Notebook
- Sound card



Device Selection Guide

Chip		Operating Voltage (Vcc)	Dissipation Current(mA)	Fiber Coupling Light Output (dBm)		
IC Material	LED p(nm)			Typ.	Min.	Typ.
Si	700	2.7~5.5	6.5	-24	-	-14.5

Technical Data Sheet- Light Receiving Unit

DATA LINK : DLR11M1

Package Dimensions

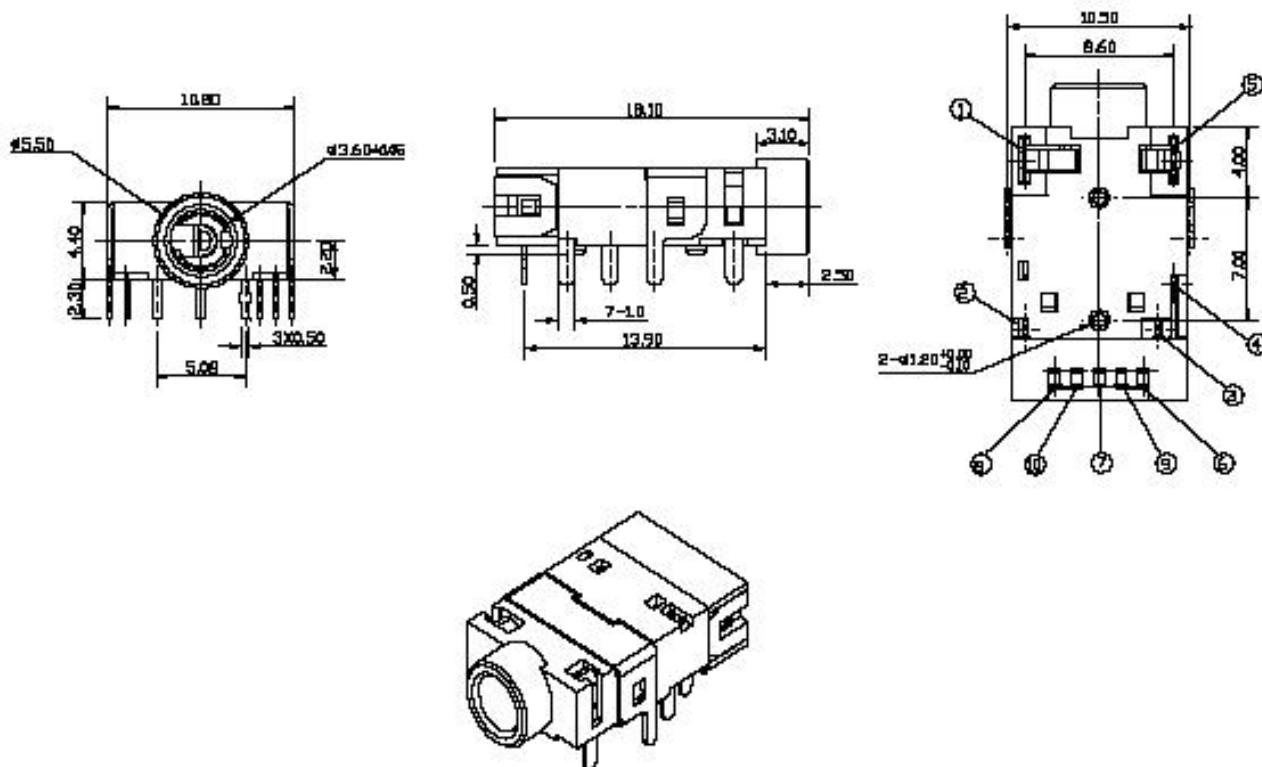

- Notes:**
- 1.All dimensions are in millimeters.
 - 2.General Tolerance:±0.2mm
 - 3.Pin 1~5 golden plating

Pin Function

- 1 ~ 5 : jack terminal (1,5 : detector ; 4: GND ; 2 : left channel ; 3 : right channel)
 6 ~ 10 : device terminal (6 : Vout ; 7 : GND ; 8 : Vcc ; 9, 10 : internal connection)

Technical Data Sheet- Light Receiving Unit

DATA LINK : DLR11M1

Jack Terminal Configuration

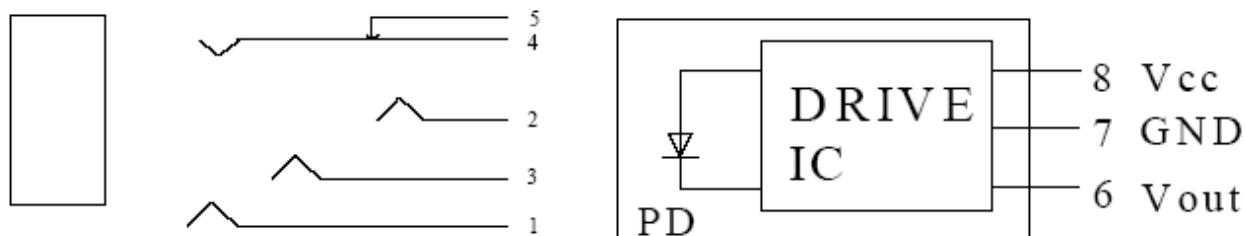

Optical Mini-jack Connection

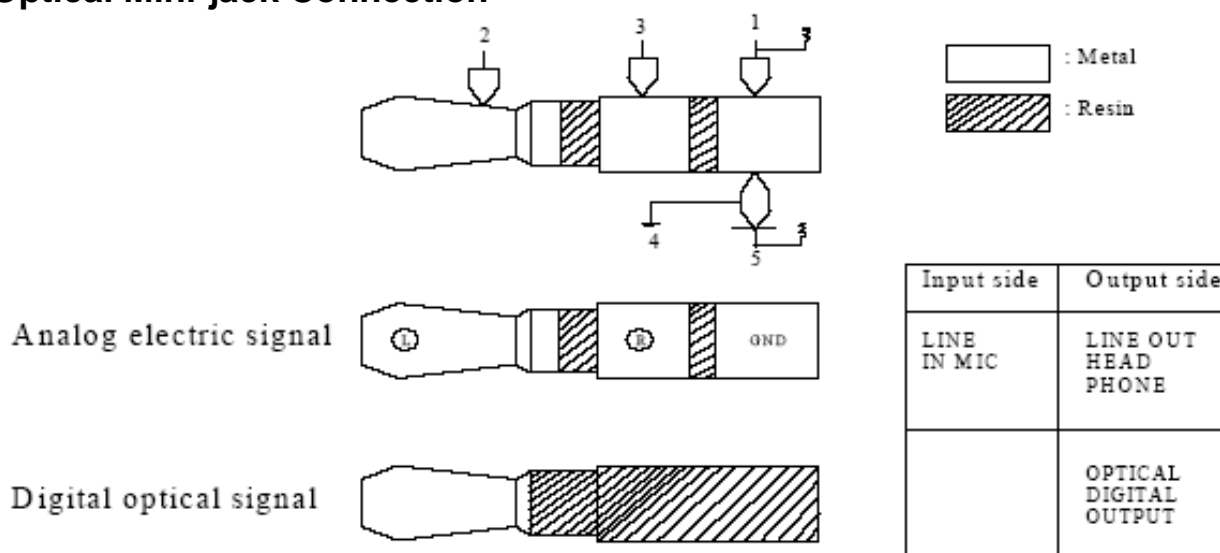

Type of plug	Output of terminal		Output of terminal
	5	1	2,3
Analog electricity	L	L	Signal data input/output
Digital optics	L	H	Signal data output
No plug	H	H	-

Absolute Maximum Ratings(Ta = 25)

Parameter	Symbol	Rating	Unit
Supply Voltage	Vcc	5.5	V
Storage Temperature	Tstg	-30 to 80	
Operating Temperature	Topr	-20 to 70	
Soldering Temperature	Tsol	260*	

* Soldering time ≤ 5 s / 2 times.

Technical Data Sheet- Light Receiving Unit

DATA LINK : DLR11M1

Electro-Optical Characteristics

Parameter	Symbol	Conditions	MIN.	TYP.	MAX.	Unit
Operating Voltage	Vcc	-	2.7	-	5.5	V
Peak Detective Wavelength	λ_p	-	-	700	-	nm
Transfer Speed		NRZ signal	0.1	-	16	Mbps
Transmission Distance		Using APF	0.2	-	20	m
Pulse Width Distortion	Δtw	16Mbps NRZ Signal	-20	-	20	ns
Fiber Coupling Light Input	Pi	*1	-24	-	-4.5	dBm
Dissipation Current	Icc	*2	-	6	10	mA
High Level Output Voltage	VOH		2.4	-	-	v
Low Level Output Voltage	VoL		-	-	0.4	v
Rise Time	t_r	*3	-	30	40	ns
Fall Time	t_f	*3	-	20	30	ns
Low → High propagation delay time	t_{PLH}	*3	-	-	100	ns
High → Low propagation delay time	t_{PHL}	*3	-	-	100	ns
Jitter	Δt_j	*3	-	1.5	15	ns

Mechanical Electro-Optical Characteristics (Jack)

Parameter	Symbo	Conditions	MIN.	TYP.	MAX.	Unit
Insertion and withdrawal force	F_p	*a	5	-	35	N
Contact resistance	Rcon	*b	-	-	30	m
Isolation resistance	Riso	D.C.500V, 1min	100	-	-	M

*a Using JIS C6560 standard plug for test.

*b It measures at 100 mA or less 1000 Hz at the condition of inserting JIS C6560 plug .

The DLR11M1 light receiving unit satisfies EIAJ CP-1201 digital audio interface standard.

Technical Data Sheet- Light Receiving Unit

DATA LINK : DLR11M1

Reliability Test Items

No.	Item	Test Condition	Test Hour/Cycle	Samples	Number (n) Failure (c)
1	Soldering Heat	260 ±5	5 sec./2times	22	n=22, c=0
2	High temp. & Hum. storage	Ta=40 , 90%RH	500	22	n=22, c=0
3	High temp. storage	Ta=80	500	22	n=22, c=0
4	Low Temp. storage	Ta=-30	500	22	n=22, c=0
5	Temp. cycling	-30 ~ 80 (30min) (5min) (30min)	20	22	n=22, c=0
6	High Temp. Operation life	Ta=60 , Vcc=5V ON	500	22	n=22, c=0
7	Repeated operation	500 times	Coupling force < 3.5kg 0.4kg<Detaching force <3.5kg	22	n=22, c=0
8	Terminal Strength(tension)	Weight: 500 g 30 sec./each terminal		22	n=22, c=0
9	Terminal Strength(bending)	Weight: 500 g 2 times/each terminal		22	n=22, c=0
10	Mechanical Shock	Acceleration: 1000m/s ² Pulse width: 6 ms 3 times/ X,Y,Z direction		22	n=22, c=0
11	Vibration	Frequency range: 10~55 Hz /sweep 1 min Overallamplitude:1.5 mm 2H./X,Y,Z direction		22	n=22, c=0

I_{cc} (dissipation current): CURRENT ATTENUATE DIFFERENCE < 20%

T_{PLH} (propagation L → H delay time): DELAY TIME DIFFERENCE < 20%

T_{PHL} (propagation H → L delay time): DELAY TIME DIFFERENCE < 20%

T_r (rise time): TIME DIFFERENCE < 20%

T_f (fall time): TIME DIFFERENCE < 20%

Technical Data Sheet- Light Receiving Unit

DATA LINK : DLR11M1

Measuring Method

*1 Measuring method of optical input coupling fiber

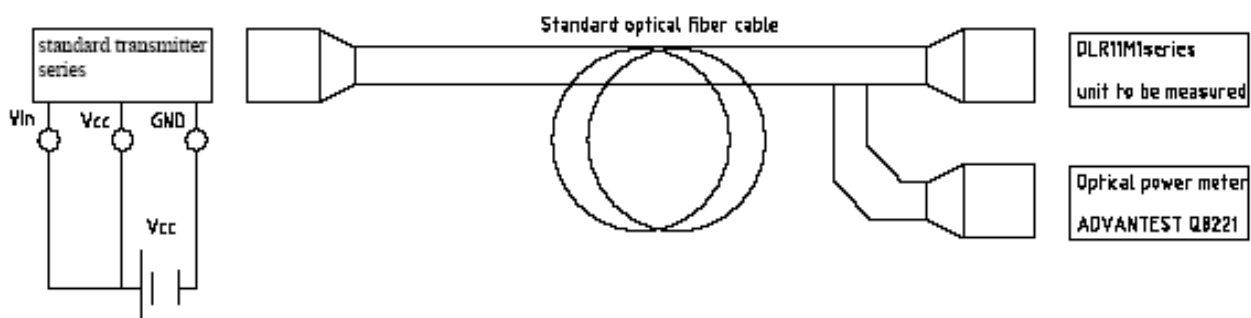

*2 Current dissipation measuring method

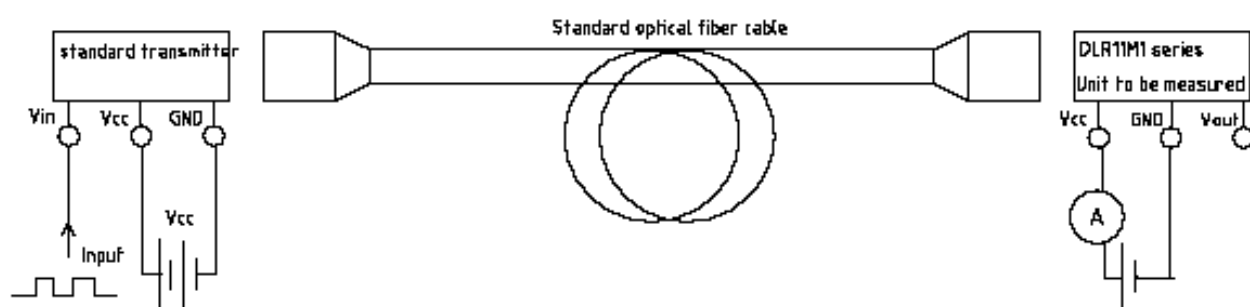

*3 Pulse response and jitter measuring method

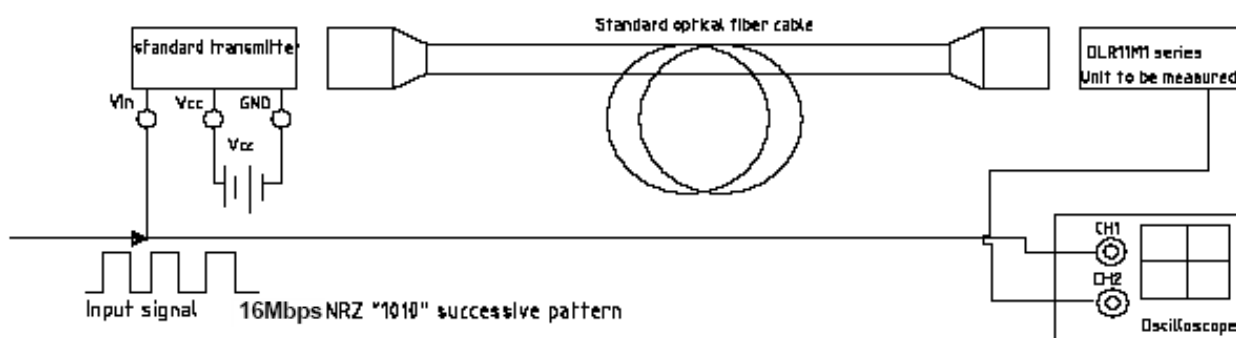

Technical Data Sheet- Light Receiving Unit

DATA LINK : DLR11M1

PCB Layout For Electrical Circuit

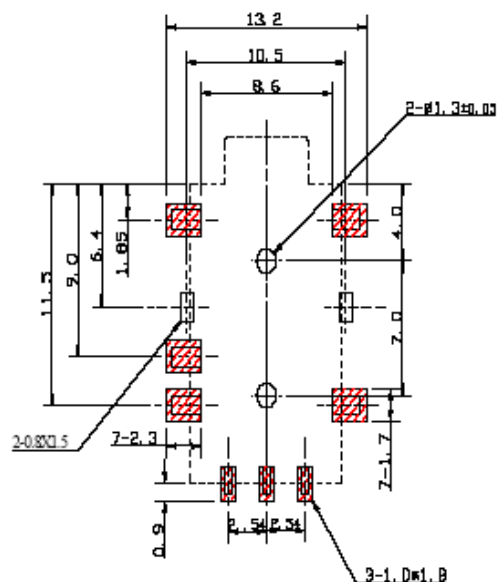

Notes:

1. Unit: mm
2. Unspecified tolerance: ± 0.3 mm
3. Substrate Thickness: 1.6mm

Precautions for Using Method

1. Connect a by-pass capacitor (0.1uF) close to the DLR11M1 within 7 mm of the unit lead frame.
2. Connect a by-pass capacitor (30pF) between GND and Vout avoid loading effect.
3. Take proper electrostatic-discharge (ESD) precautions while handling these devices. These devices are sensitive to ESD.

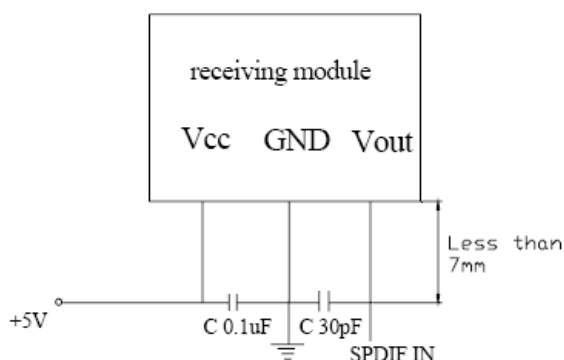

Technical Data Sheet- Light Receiving Unit

DATA LINK : DLR11M1

Material Description

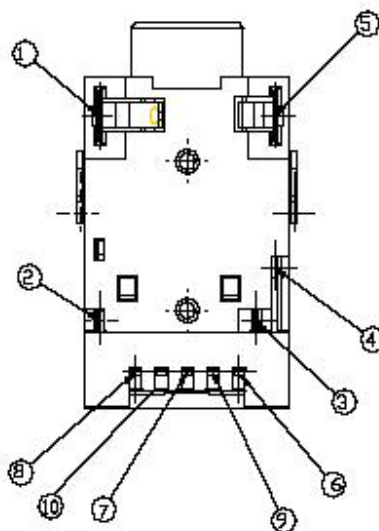
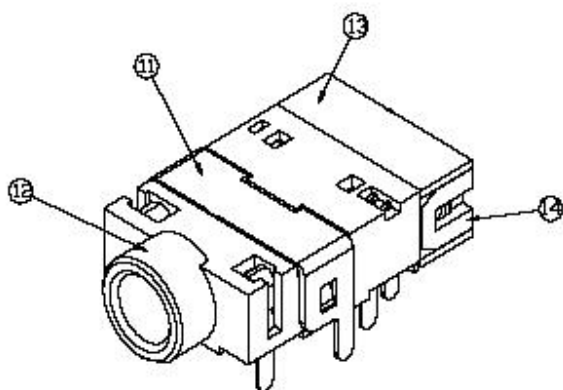

ITEM	NAME	MATERIAL	FINISH	NOTE
1	Ground	PBS	Au	
2	Tip	Cu+Ti	Au	
3	Ring	PBS	Au	
4	GND	Cu+Be	Au	
5	Shunt	PBS	Au	
6	GND	PBS	Tin	
7	Vcc	PBS	Tin	
8	Vin	PBS	Tin	
9	Connection	PBS	Tin	
10	Connection	PBS	Tin	
11	Shield	BRASS	Tin	
12	Housing	PA-9T		UL94V-0
13	Switch Housing	PA-9T		UL94V-0
14	Cover	PA-9T		UL94V-0

Technical Data Sheet- Light Receiving Unit

DATA LINK : DLR11M1

Package

Item	Quantity	Total	Size (long*width*high)
Tray	1	150 pcs	28.5*28.5*1.08 cm
Inner box	10 tray/box	1500 pcs	29*29*14cm
Outer box	2 inner box/outer box	3000 pcs	60*31*17.8 cm

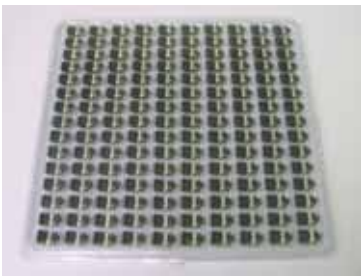

150 pcs/tray
(28.5*28.5*1.08 cm)

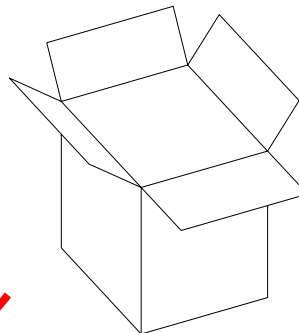
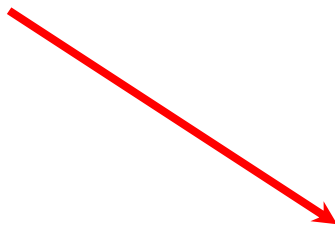

10 tray/box(1500pcs)
(29*29*14cm)

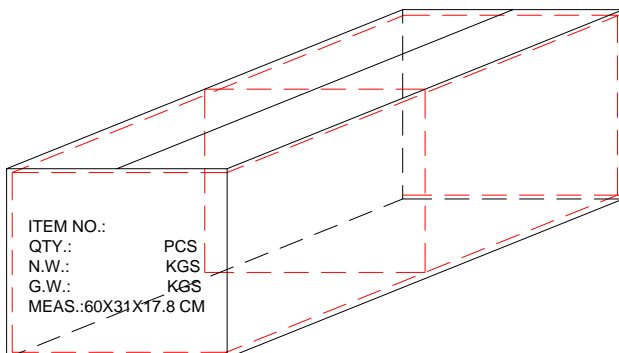
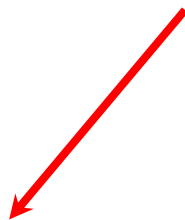

2 inner box/outer box (3000pcs)
(60*31*17.8cm)

Technical Data Sheet- Light Receiving Unit
DATA LINK : DLR11M1

REV	DESCRIPTION	RELEASE DATE