

F E D C B A

ZONE	SYMBOL	REVISION	APPROVAL	DATE
		ADD MATE PLUG	J.X.KUANG	29-9-2006

RoHS
Compliant

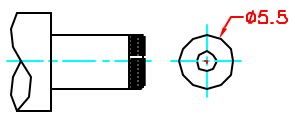
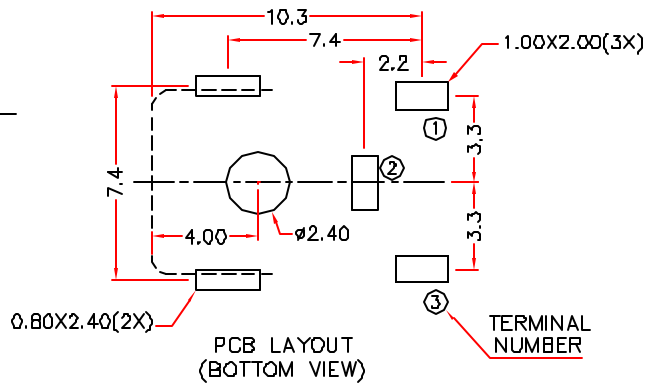
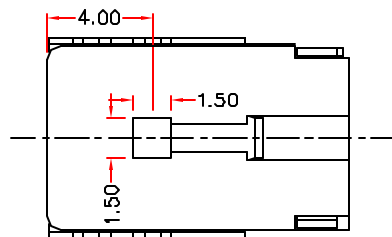
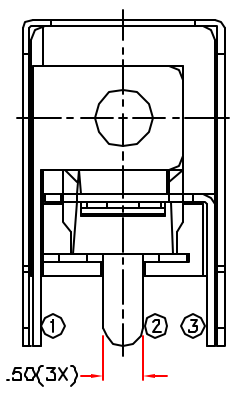
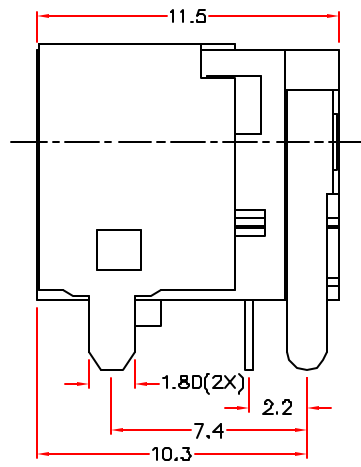
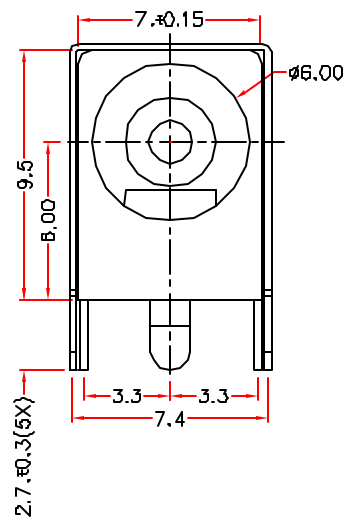
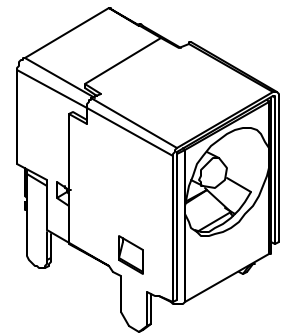

DC MATE PLUG

MODEL NO.	HDC-803HS
SCHEMATIC	
CENTER PIN	ø1.65mm
	ø2mm
	ø2.5mm

*** MATERIAL**
 CENTRE PIN : COPPER
 TERMINAL 1 : BRASS
 TERMINAL 2 : COPPER ALLOY
 TERMINAL 3 : BRASS
 SHIELD : BRASS
 HOUSING : PBT

TERMINAL NUMBER

HUAI YANG CO.,LTD. 淮洋有限公司 TEL:886-2-8261-0858

DESIGN	J.X.KUANG	DATE	5-1-2005	SCALE	4:1
DRAWING	L.L.ZHANG	DATE	29-9-2006	MATERIAL	*
CHECK		DATE		DWG. NO.	TZ\DC038HS-PBT/B
APPROVAL		DATE		SHEET	

PART NAME	HIGH CURRENT DC POWER SOCKET	TOLERANCE UNLESS	0.0±0.2	UNIT:	
PART NO.	HDC-803HS	OTHERWISE SPECIFIED:	0.00±0.1 0.000±0.05	mm	

F E D C B A DCF-04/A