

HISTORY X COUNT	DATE (YYYY.MM.DD)	ECN NO.	REV.	REVISION	SIGN.
---	2012.03.02	---	1.0	New Drawing	黄福堂

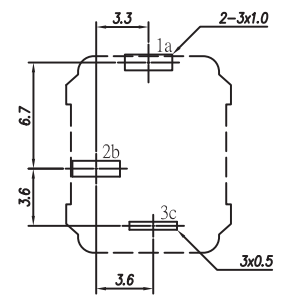

TOL: ±0.1
 PCB t=1.6
 PCB LAYOUT
 BOTTOM VIEW

MODEL	DJ-0703C#020	DJ-0703C#025
CENTER PIN DIMETER φA	2.0 DIA	2.5 DIA
SCHEMATIC		

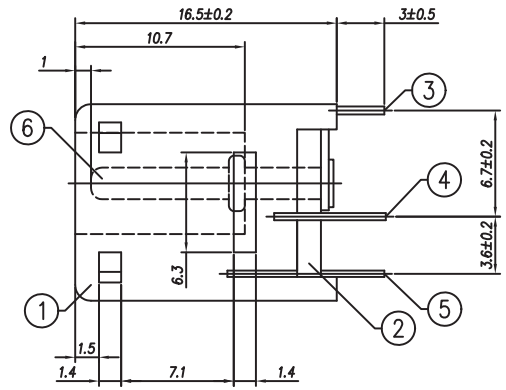
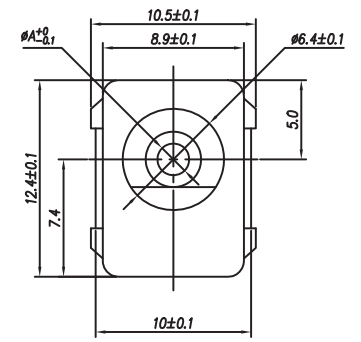
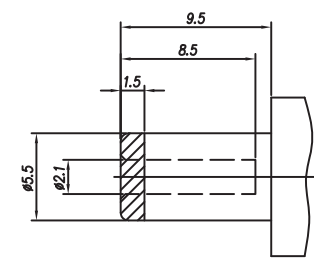
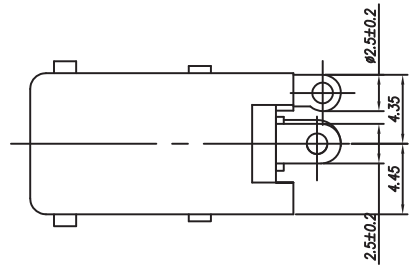

Mating Plug

NO.	MODEL	PART NO.	MATERIAL	φA
2	0703C#025	0703B-73-cXN	BRASS	φ2.5
1	0703C#020	0703B-72-cXN	BRASS	φ2.0

TABLE B: Model of Center Pin

NO.	PIN	Table B	QTY	Table B	Ni: 3~4μm	See Table
6	PIN	Table B	1	Table B	Ni: 3~4μm	See Table
5	NO. 3 PIN	0703-33-eXX	1	PHOSPHOR BRONZE	Ag: 0.3~1μm	t=0.25
4	NO. 2 PIN	0703-32-bXX	1	BRASS	Ag: 0.3~1μm	t=0.35
3	NO. 1 PIN	0703-31-bXX	1	BRASS	Ag: 0.3~1μm	t=0.5
2	BOARD	0703C-52-z-B	1	BAKEUTE	BLACK	(RoHS Fit), 94HB
1	BODY	0703A-01-αXW3	1	P.B.T+15%GF	WHITE	(RoHS Fit)
NO.	PART NAME	PART NO.	QTY	MATERIAL	PLATED / COLOR	REMARK

TABLE A : Parts of Product

NOTICE	PLATED/COLOR	ANGLE TOL.	SCALE	RoHS Complied		SIZE	
	See Table	±2°	3/1				A3
	THICKNESS	TOLERANCE	UNIT	SPECIFICATION		REV.	
	See Table	±0.3	mm				1.0
	MATERIAL	ANGLE	ORIGINAL DATE (YYYY.MM.DD)	PART NAME			1.0
See Table	3rd	2012.03.02	DC POWER JACK				
DESIGNED	DRAWN	CHECKED	APPROVED	PART NUMBER	DWG. NO	SHEET	
黄福堂	黄福堂	游大成	游大成	0703C#XXX	0703C-A001	1/1	
2012.03.02	2012.03.02	2012.03.05	2012.03.05	淮洋有限公司 HUAI YANG CO., LTD.			