

HISTORY X COUNT	DATE (YYYY.MM.DD)	ECN NO.	REV.	REVISION	SIGN.
---	2010.08.04	---	1.0	New Drawing	黄福堂
△X10	2011.11.15	N11B010	1.1	Drawing Update	黄福堂

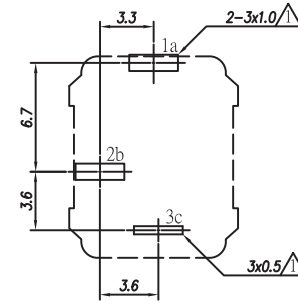

TOL: ±0.1  
 PCB t=1.6  
 PCB LAYOUT  
 BOTTOM VIEW

MODEL	DJ-0703A*020	DJ-0703A*025
CENTER PIN DIMETER φA	2.0 DIA	2.5 DIA
SCHEMATIC		

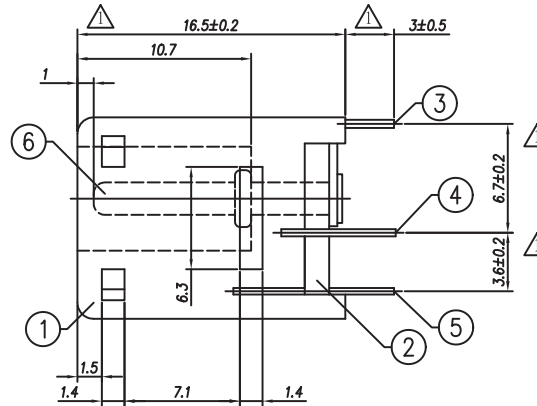
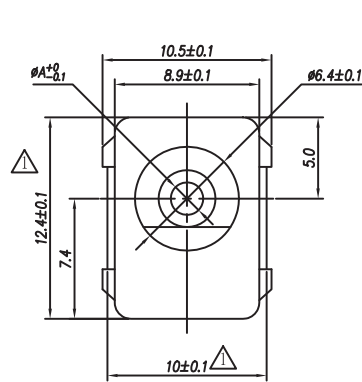
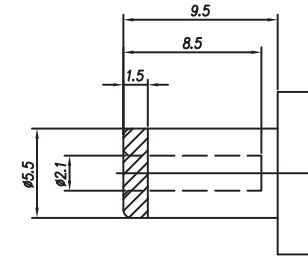
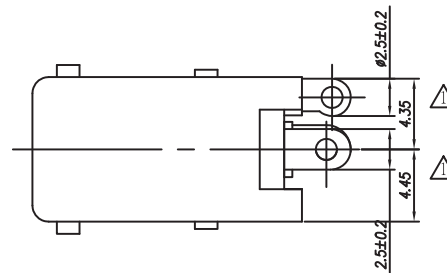

Mating Plug

NO.	MODEL	PART NO.	MATERIAL	φA
2	0703A*025	0703B-73-cXN	BRASS	φ2.5
1	0703A*020	0703B-72-cXN	BRASS	φ2.0

TABLE B: Model of Center Pin

NO.	PART NAME	PART NO.	Q'TY	MATERIAL	PLATED / COLOR	REMARK
6	PIN	Table B	1	Table B	Ni: 3~4 μm	See Table
5	NO. 3 PIN	0703-33-eXX	1	PHOSPHOR BRONZE	Ag: 0.3~1 μm	t=0.25
4	NO. 2 PIN	0703-32-bXX	1	BRASS	Ag: 0.3~1 μm	t=0.35
3	NO. 1 PIN	0703-31-bXX	1	BRASS	Ag: 0.3~1 μm	t=0.5
2	BOARD	0703C-52-z-B	1	BAKEUTE	BLACK (RoHS Fit), 94HB	
1	BODY	0703A-01-aXB	1	P.B.T+1580F OR EQUIV.	BLACK (RoHS Fit)	

TABLE A : Parts of Product

NOTICE	PLATED/COLOR	ANGLE TOL.	SCALE	RoHS Complied		SIZE
	See Table	±2°	3/1			A3
	THICKNESS	TOLERANCE	UNIT	SPECIFICATION		REV. 1.1
	See Table	±0.3	mm			
	MATERIAL	ANGLE	ORIGINAL DATE (YYYY.MM.DD)	PART NAME		REV. 1.1
	See Table	3rd	2010.08.04	DC POWER JACK		
	DESIGNED	DRAWN	CHECKED	APPROVED	PART NUMBER	DWG. NO
	黄福堂 2011.11.15	黄福堂 2011.11.15	游大成 2011.11.15	游大成 2011.11.15	0703A*XXX	0703A-A003
淮洋有限公司 HUAI YANG CO., LTD.						SHEET 1/1