

REV.	LTR.	DESCRIPTION	SIGN	DATE

DC 0 1 3 9 0 - A PB 0A S 0

(1) (2) (3) (4) (5) (6) (7) (8)

- (1): Series type:
- (2): Series No.
- (3): Schematic option: A
- (4): Material of housing:
PB=PBT (Standard)
- (5): Housing color:
Zero—0A=Black
- (6): Terminal plating:
S=Silver (Ag)
- (7): Special option:
0=No special option
- (8): Packing mode:
1: Reel packing
3: Plastic box packing
4: Bag packing

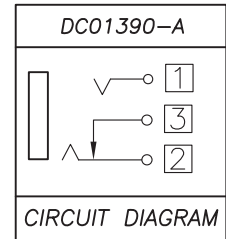
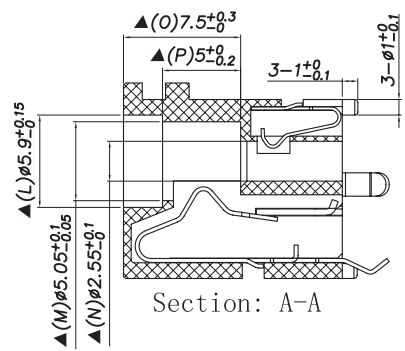
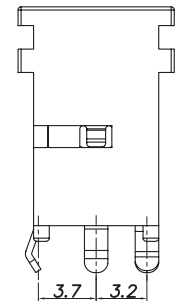
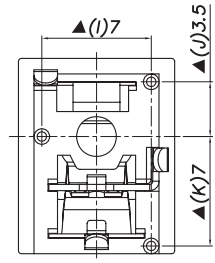
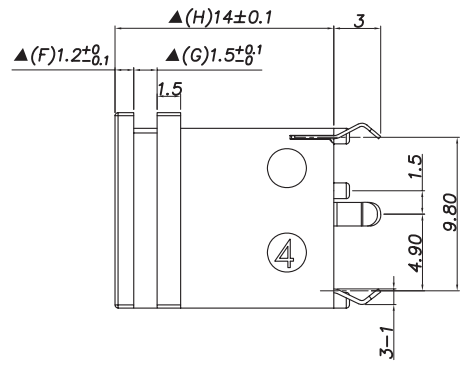
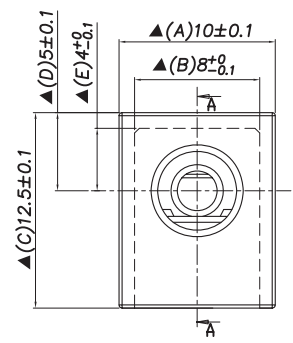
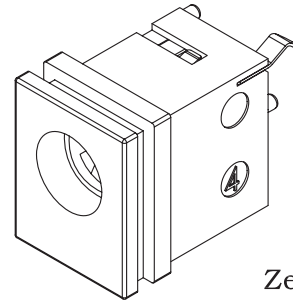

□ : TERMINAL NO.

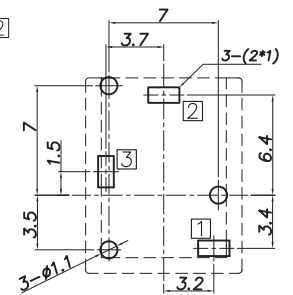
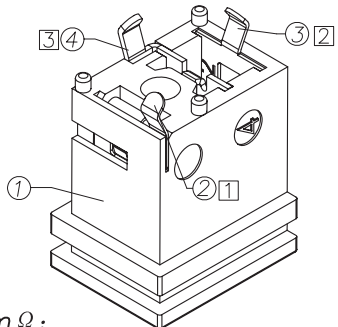
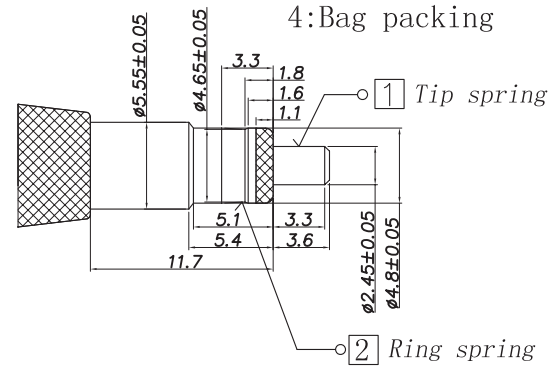

P. C. B Layout (Copper-sided view)

SPECIFICATION

- 1. Rating : DC 6.3V 2.0A;
- 2. Contact resistance: $\leq 30m\Omega$;
- 3. Insulation resistance: $\geq 100M\Omega$ (DC500V);
- 4. Withstand voltage: 500VAC ;
- 5. Insertion force: $\leq 20N$;
Extraction force: 3-15N
- 6. life test: 5,000 cycles.

④	Shunt terminal	③	1	Brass t=0.4	DC01390-03	Silver plating
③	Ring spring	②	1	Phosphor bronze t=0.25	DC01390-02	Silver plating
②	Tip spring	①	1	Phosphor bronze t=0.2	DC01390-01	Silver plating
①	Housing		1	PBT+30%GF	DC01390-S1	Black
NO.	DESCRIPTION	QTY	MATERIAL	PART NO.	PLATING	
UNIT:MM		TYPE:		MODEL NO:		PAPER NO: A4
TYPE:		MODEL NO:		PAGE 1 OF 1		
DC POWER JACK		DC01390-APB0AS0_		TOLERANCE	ANGLES	SCALE
DESIGNER BY:		Wangyan 2009.07.22		±0.3	±2'	FULL
CHECK BY:				VER		
APPROVED BY:				00		

淮洋有限公司 HUI YANG CO., LTD.
www.hy1688.com.tw TEL:886-2-82618986