

P. C. B Layout (TOP view)

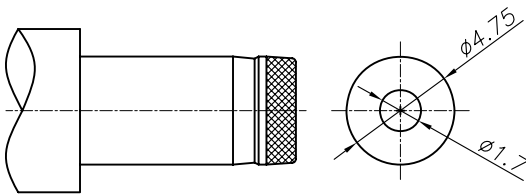

DC MATE PLUG

- DC 0 1 1 6 B - A G 9T 0A S 0 1
 (1) (2) (3) (4) (5) (6) (7) (8) (9)
- (1): Series type: DC=DC POWER JACK
 - (2): Series No.
 - (3): Schematic option: A
 - (4): Center pin diameter:
G: $\phi 1.65$
 - (5): Material of housing:
9T=PA9T (Standard)
 - (6): Housing color:
0A=Black
 - (7): Terminal plating:
S=Silver (Ag)
 - (8): Special option:
0=No special option
 - (9): Packing mode:
1=Reel packing

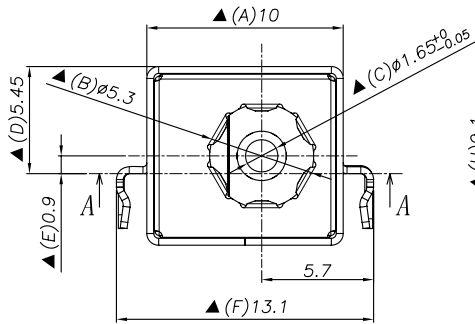
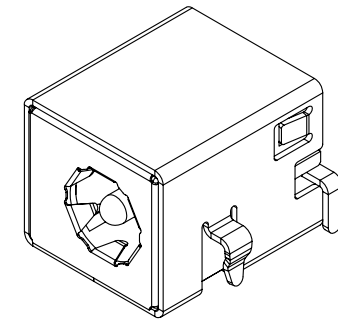
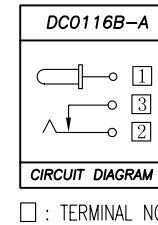

SPECIFICATION

1. Rating : DC 20V 7A;
2. Contact resistance: $\leq 30m\Omega$,
After life test: $\leq 50m\Omega$;
3. Insulation resistance: $\geq 100M\Omega$ (DC500V),
After life test: $\geq 50M\Omega$;
4. Withstand voltage: 500VAC ;
5. Insertion and extraction force: 3-30N;
6. life test: 5,000 cycles;
7. Operation temperature range: $-20^{\circ}C \sim 70^{\circ}C$;
8. Preservative temperature range: $-40^{\circ}C \sim 85^{\circ}C$;
9. Sign "▲" is importance dimension.

7	Ground terminal	1	SUS301 t=0.1	DC0116B-E1	
6	Shield	1	Brass t=0.35	DC01160-W1	Ni 50u"Min
5	Terminal	1	Brass t=0.4	DC01160-04	
4	Shunt terminal	3	Brass t=0.4	DC01160-03	Ag 20u"Min, Ni 20u"Min
3	Tip spring	2	Brass t=0.3	DC0116B-02	Ag 20u"Min, Ni 20u"Min
2	Center pin	1	Zn alloy	DC0116B-99G	Ni 50u"Min
1	Housing	1	PA9T UL94V-0	DC0116B-S1	
NO.	DESCRIPTION	QTY	MATERIAL	PART NO.	PLATING

UNIT: MM	TYPE:	MODEL NO:	PAPER NO: A4	PAGE 1 OF 1
	DC POWER JACK	DC0116B-AG9T0AS01	TOLERANCE	ANGLES
			± 0.3	$\pm 2'$
			SCALE	VER
			FULL	0

DESIGNER BY: Li Wenhui 2010.3.11
 CHECK BY:
 APPROVED BY:

淮洋有限公司 HUI YANG CO., LTD.
 www.hy1688.com.tw TEL:886-2-82618986