

REV. LTR.	DESCRIPTION	SIGN	DATE

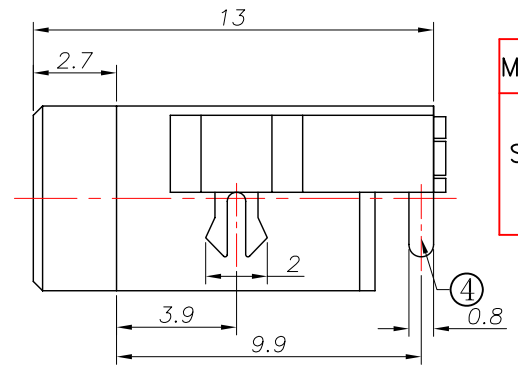
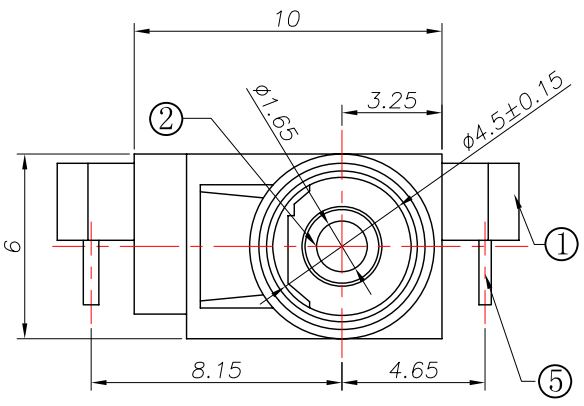

Model NO.	DC00810-B
Schematic	

Ordering information:
DC00810-B G ST **T 0**
 ① ② ③ ④ ⑤ ⑥ ⑦ ⑧

①:Series No
 ②:Schematic option:
 B
 ③:Center pin diameter:
 G=1.65
 ④:Material of housing:
 ST=PA46 (Only)
 ⑤:Housing color:
 0A=Black (Standard) 2_=Red
 3_=Orange 4_=Yellow
 5_=Green 6_=Blue
 9_=White
 ⑥:Terminal plating
 T=Tin(Sn)(Standard)
 S=Silver(Ag)
 G=Gold(Au)
 ⑦:Special option
 0:No special option
 ⑧:Packing mode:
 1:Reel packing
 4:Bag packing

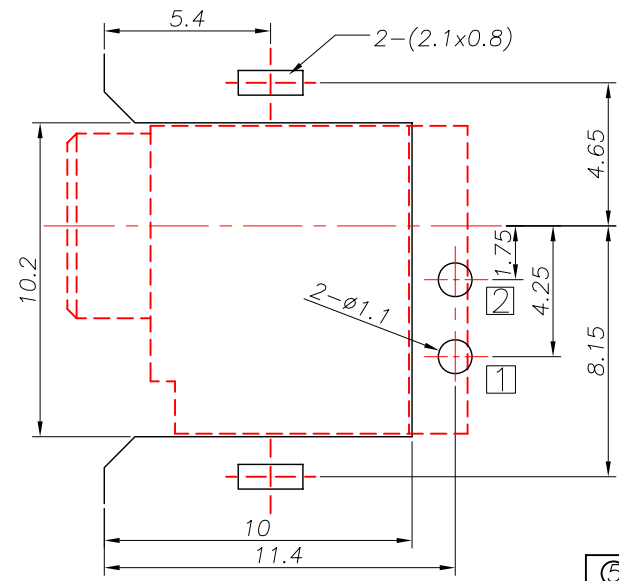
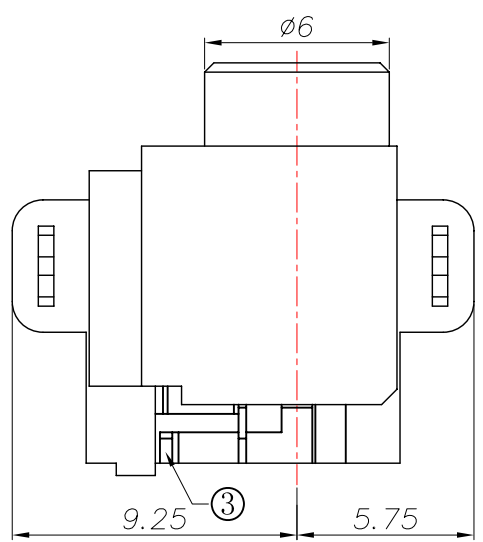

P. C. B Layout
(Copper-sided view)

SPECIFICATION

- Rating : DC 20V 6A;
- Contact resistance: ≤30mΩ;
- Insulation resistance: ≥100MΩ (DC250V);
- Withstand voltage: 500VAC ;
- Insertion and extraction force: 3-30N;
- life test: 5,000 cycles.

⑤	Hook	1	Brass	DC00810-HK(PP-1004)	Sn-Plating
④	Tip spring	1	Bronze	DC00810-02(TP-1003)	Sn-Plating
③	Center pin terminal	1	Brass	DC00810-01(WP-1002)	Sn-Plating
②	Center pin	1	Brass	DC00810-88(YZ-1005)	Sn-Plating
①	Housing	1	PA46	DC00810-S1(ST-1001)	
NO.	DESCRIPTION	QTY	MATERIAL	PART NO.	PLATING

UNIT:MM	TYPE:	MODEL NO:	PAPER NO: A4	PAGE 1 OF 1
	DC POWER JACK	DC00810-BGST__T0_	TOLERANCE	ANGLES
			±0.3	±2°
			SCALE	VER
			FULL	2

DESIGNER BY: *Shuhong 2008/7/22*
 CHECK BY:
 APPROVED BY:
 淮洋有限公司 HUAIYANG CO., LTD.
 www.hy1688.com.tw TEL:886-2-82618986