

REV. LTR.	DESCRIPTION	SIGN	DATE
	Proposal drawing	Matt	2013.06.15

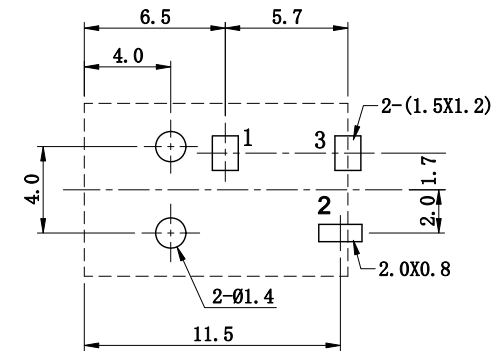

**RECOMMENDED P.C.B LAYOUT**  
TOP VIEW, TOLERANCES:±0.05mm

- SPECIFICATION**
- Rating : DC 30V 0.5A;
  - Contact resistance : ≤30mΩ;
  - Insulation resistance : ≥100MΩ (DC250V);
  - Withstand voltage : 500VAC ;
  - Insertion and extraction force : 3-25N;
  - life test : 5,000 cycles.

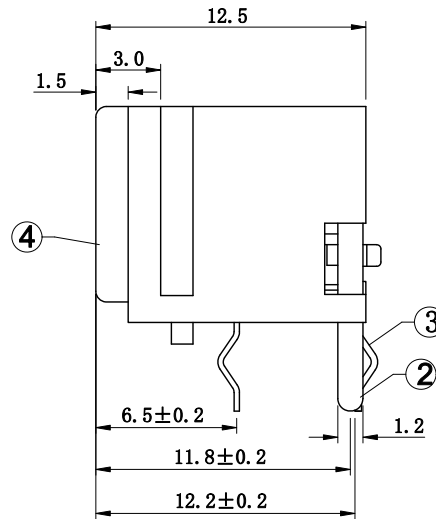
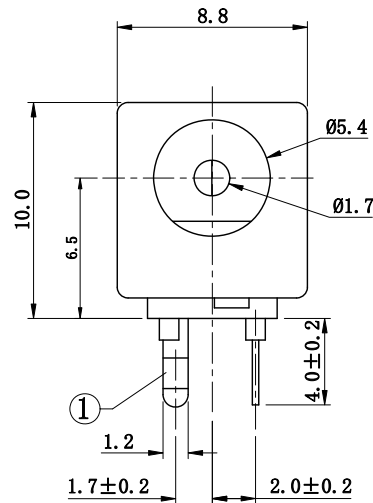
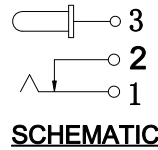

4	HOUSING	1	PBT	
3	FLAT PIECE	1	BRASS	Ag-Plating
2	CURVE PIECE	1	BRASS	Ag-Plating
1	SPRING	1	BRONZE	Ag-Plating
NO.	DESCRIPTION	QTY	MATERIAL	PLATING
UNIT:MM		TOLERANCE		TYPE:
		DIMENSIONS	ANGLES	DC JACK
		.X ±0.50	.X ±5°	
		.XX ±0.30	.X ±3°	
.XXX±0.15		.XX ±2°	MODEL NO: DC0028A-APPB0A504	
DRAWING TYPE: CUSTOMER DRAWING		DRAWING No:		SCALE: VER.: PAGE: N/A 1 1/1
DESIGNER BY: MATT 2013.06.15		CHECK BY: Sunny 2013.06.15		淮洋有限公司 HUI YANG CO., LTD. www.hy1688.com.tw TEL:886-2-82618986
APPROVED BY: JGG 2013.06.15				