

# 2255 SERIES BATTERY HOLDER

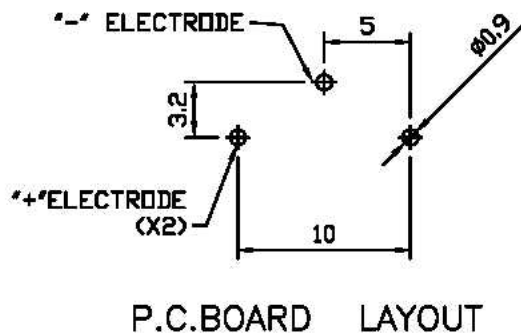

NOTE: P.C.B LAYOUT TOLERANCE:  $\pm 0.05\text{mm}$

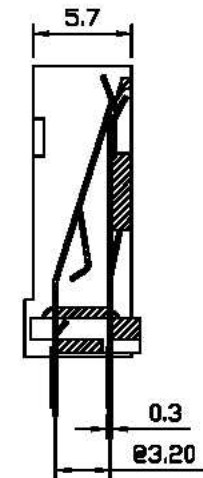
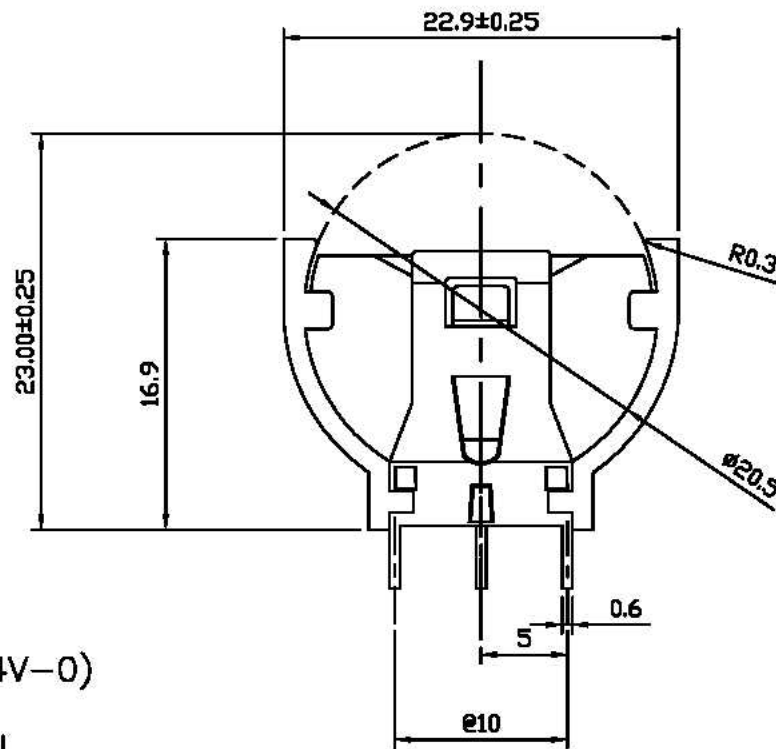

HOUSING: NYLON 66 +GF (UL94V-0)  
 CONTACT: PHOSPHOR BRONZE  
 FINISH: TIN PLATED OVER NICKEL

GS261 - 02 1 X

BATTERY DIM  
 02: D=23.5mm  
 T=5.0mm

COLOR:  
 1: BLACK

PLATING  
 1: Sn/Pb 90/10 100u" MIN  
 OVER 50U" MIN NICKEL  
 G: RoHS

UNIT: mm

NOTES				HUI YANG CO.,LTD.	
<b>CUSTOMER DRAWING</b>				TEL:886-2-82610858	
				Date: 08/23/006	Sheet: 1 of 1
A RELEASE		Date: 07/30/006	General Tolerances: Angle: $\pm 2^\circ$	Dim: 0.0 ±0.25 0.00 ±0.20 0.000 ±0.10	Drawn by
REV	Revision Record	Date	Drawn by	Checked by	Title
Review Only On Call System			App'd by	Scale: 1:1	<b>BATTERY HOLDER</b>