

**NOTES**

- MATERIALS:**  
HOUSING-PBT 30%GF UL94V-0.  
CONTACT-PHOSPHOR BRONZE, C5191R-H T=0.6mm.
- FLASH:** 0.25mm MAX.
- CAMBER:** 0.13mm MAX. **DEFORMATION:** NA.  
**WARP:** 0.13mm MAX. **TWIST:** NA.
- ORDER INFORMATION:**

GS025-XX X X

**PLATING:**

- TIN 100u" MIN OVER Ni 50u" MIN.
- Ni 80u" MIN.

**COLOR:**  
1.BLACK

**BATTERY DIM.**

- 01: D=19.8, T=3.2  
02: D=22.8, T=3.2

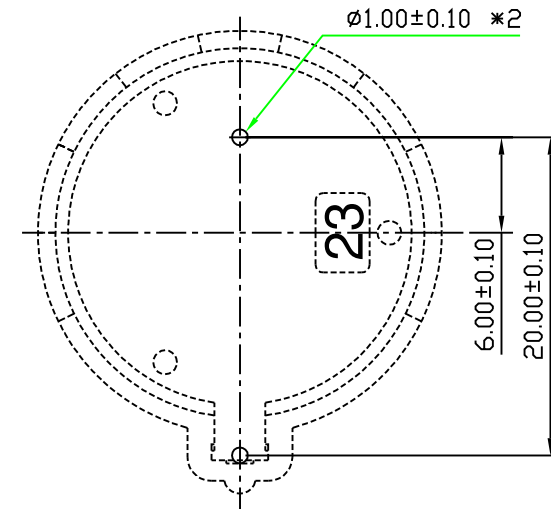

**RECOMMEND PCB LAYOUT  
COMPONENT SIDE**

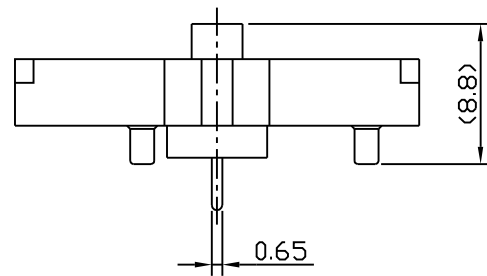
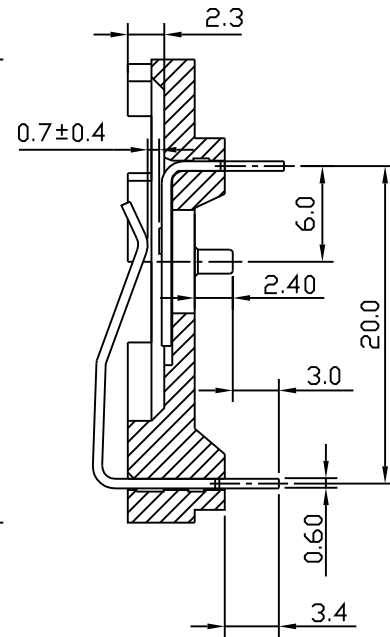
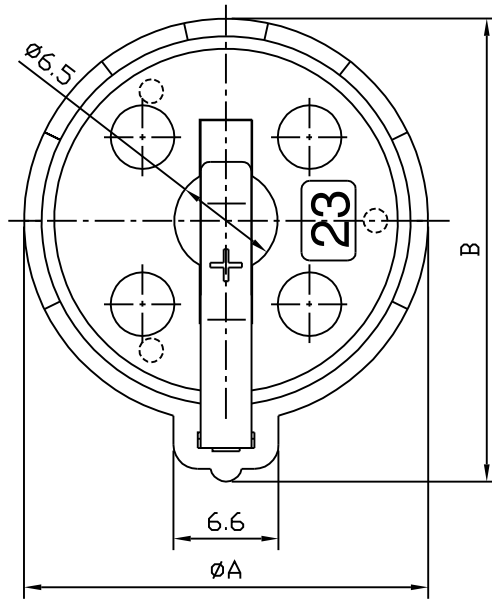

PART NO	ØA	B
GS025-01**	22.8	27.8
GS025-02**	25.4	29.0

		<b>CUSTOMER DRAWING</b>		HUAI YANG CO., LTD.	
		UNIT: mm		TEL:886-2-82610858	
		General Tolerances: Angle: ±2°		Date: 04/12/02'	Sheet 1 of 1
A RELEASE		04/12/02'		DWG. NO: GS025-XX X X REV: A	
REV	Revision Record	Date	Drawn by	Chk'd by	Title:
Revise Only On Cad System			App'd by	Scale	<b>BATTERY HOLDER ASS'Y</b>
			2 : 1		