

REV.	ECN NO. / DESCRIPTION	DATE
1	N040040	02/10'04
2	N050146	5/20'05

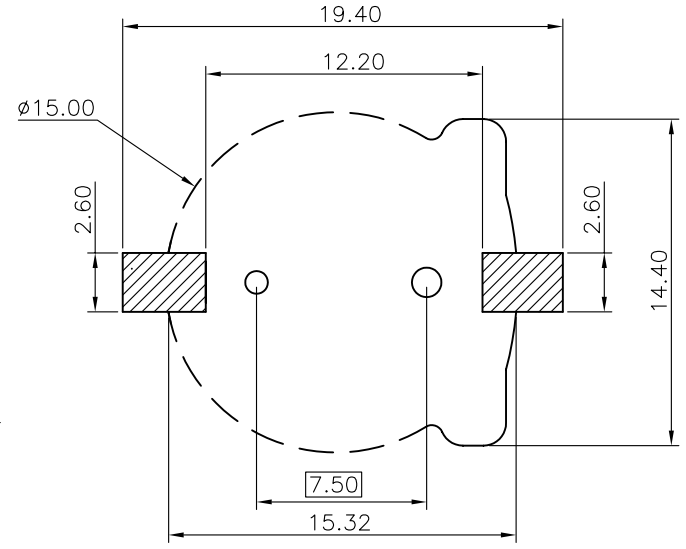

RECOMMENDED PCB LAYOUT

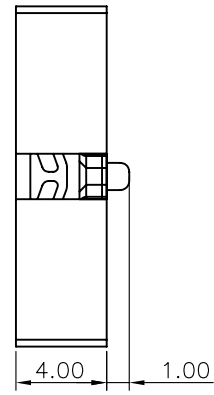
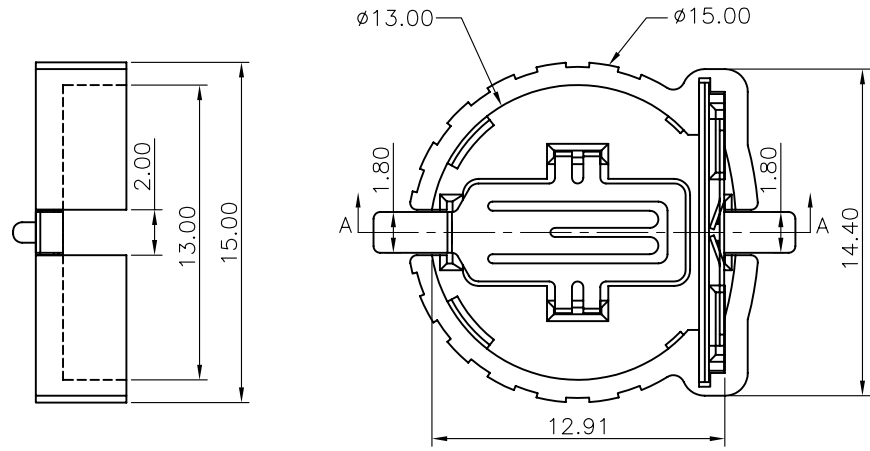
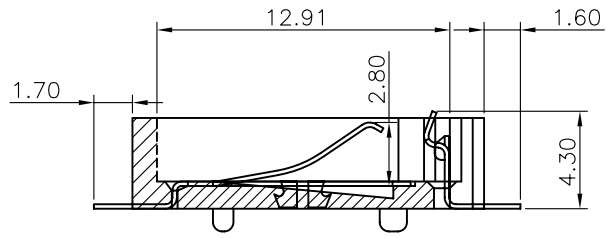
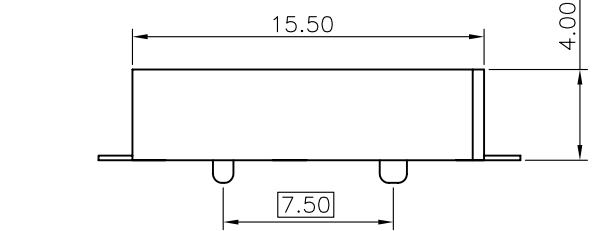

SECTION A-A

- NOTES:
- 1.DIMENSIONS ARE IN MILLIMETERS
 - 2.MATERIAL:
PLASTIC PART:PPS WITH 30% GLASS FIBER,
UL94V-0,BROWN;
CONTACT:COPPER ALLOY.
 - 3.FINISH:
CONTACT:GOLD PLATED ALL OVER THE FACE

GENERAL TOLERANCES UNLESS SPECIFIED		PART NO.	HUAI YANG CO.,LTD.		
.X ±0.35	X.° ±3°	B6810AP2L	TITLE BATTERY HOLDER FOR CR1220		
.XX ±0.25	.X.° ±2°	APPROVE	DWG NO. B68QCL001		
.XXX ±0.15	.XX.° ±1°	CHECK	DRAW		
CUSTOMER DRAWING		LI TING 5/20'05	SHEET SCALE REV		
SIZE	UNITS				
A4	MM[INCH]				