

REV.	ECN NO. / DESCRIPTION	DATE
2	N050146	5/20'05
2A	R080121	2/27'08

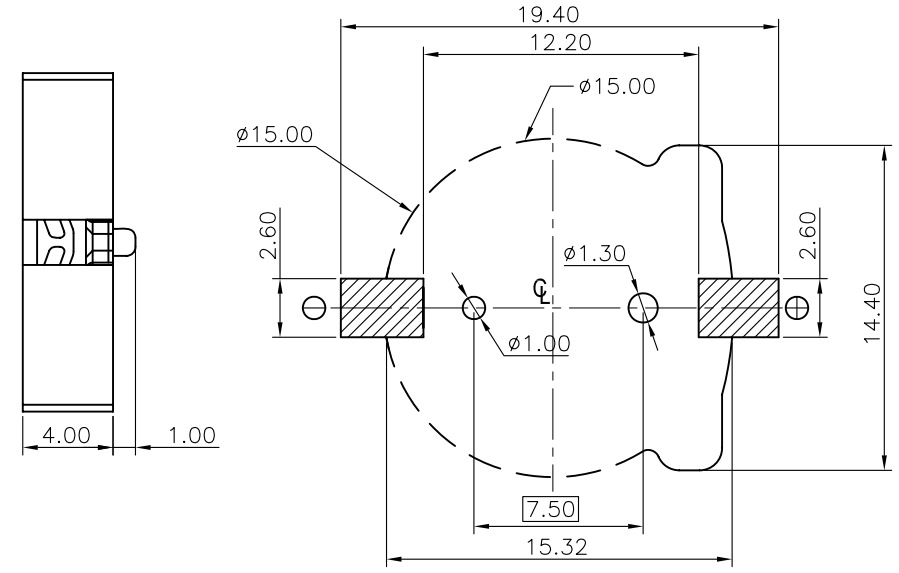
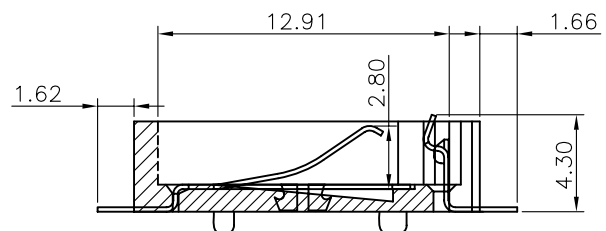
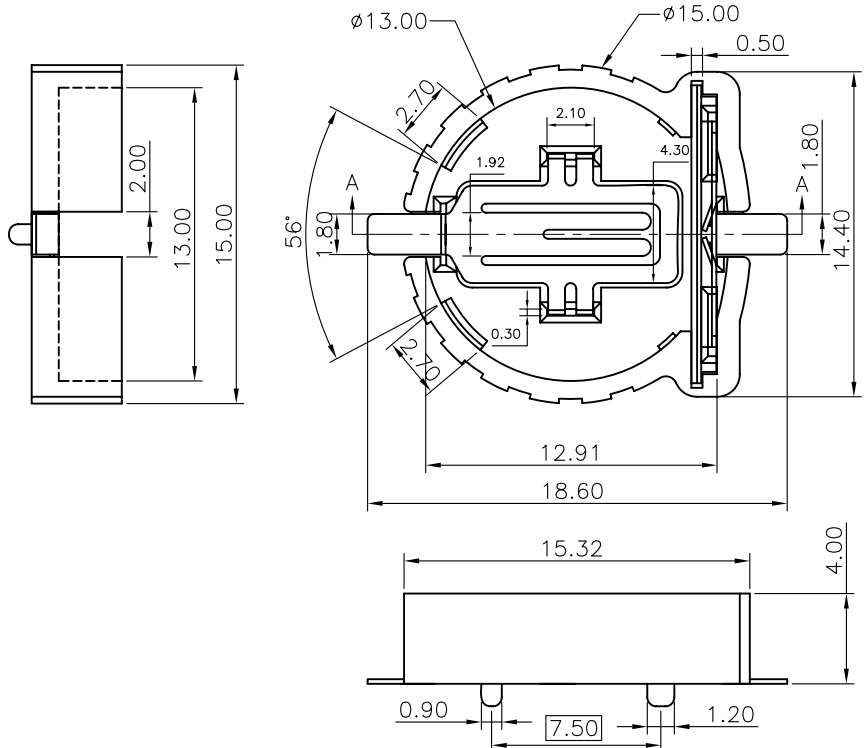

RECOMMENDED PCB LAYOUT

- NOTES:
- 1.DIMENSIONS ARE IN MILLIMETERS.
 - 2.MATERIAL:
PLASTIC PART:PPS WITH 30% GLASS FIBER_COFFEE.
CONTACT:COPPER ALLOY.
PACKING:REEL_PACKING.
 - 3.FINISH:
CONTACT:NI50u'' UNDERPLATING, GOLD PLATED ALL OVER THE FACE.
 - 4.RoHS COMPLIANT.

GENERAL TOLERANCES UNLESS SPECIFIED		PART NO. SEE TABLE	HUAI YANG CO.,LTD.			
.X ±0.35	X° ±3°					
.XX ±0.25	X° ±2°	APPROVE Smark_Huo	TITLE BATTERY HOLDER FOR CR1220			
.XXX ±0.15	.XX° ±1°	CHECK Joe_Peng	DWG NO. KB68QCL001			
CUSTOMER DRAWING		DRAW zhangyusheng		SHEET	SCALE	REV
SIZE A4	UNITS MM[INCH]			1 / 1	3:1	2A

AAA-BAT-044-K01_A	REEL_PACKING
KB6810AP2L	TRAY_PACKING